

EGIS

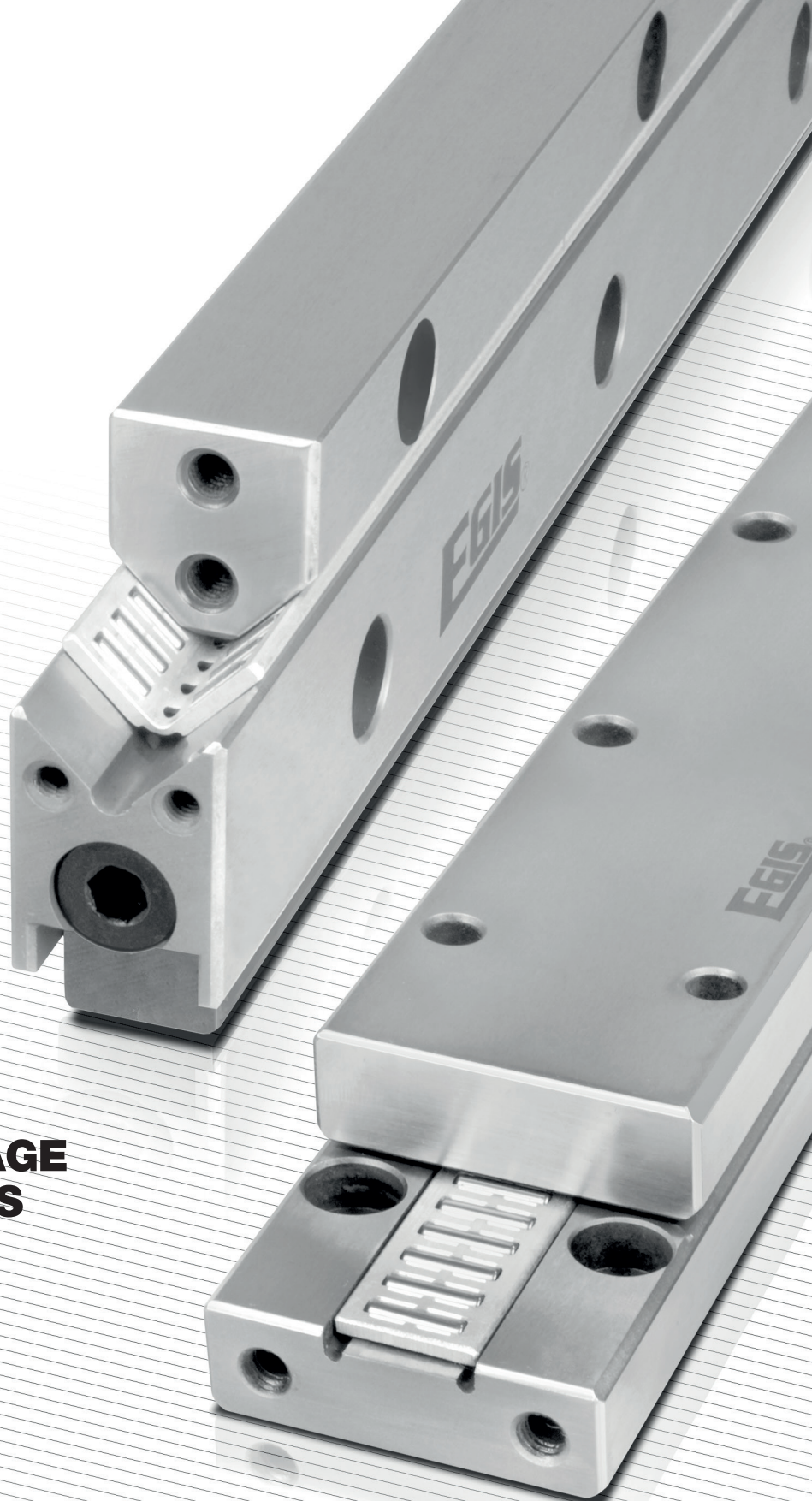

**PRECISION FLAT CAGE
GUIDANCE SYSTEMS**



Linear guidance systems with rolling elements

have established a position for themselves in the machine building industry as have roller bearings for rotary motion. They are essential wherever the requirement is smooth running combined with minimal construction and maintenance expenditure. Characteristics such as load carrying capacity, rigidity and precision also have an important role to play. Moreover, a wide range of tailor-made solutions are required which have to be adapted to each individual construction requirement.

If a high level of precision, load carrying capacity and rigidity are required, as is generally the case with machine tools, precision linear guidance systems with needle or cylindrical roller flat cage assemblies without recirculating rolling elements offer an optimum solution. Compared with other linear systems, they require a smaller construction space, are used as locating or non-locating bearings depending on the configuration and are suitable for high accelerations. Due to the relative movement of the cage along the two raceways, they are particularly suitable for limited strokes. In contrast to linear guidance systems with recirculating rolling elements, the rolling elements are positioned between the raceways throughout the entire motion sequence. This guarantees exceptionally quiet running and a high level of running accuracy.

If specific space requirements are taken into account, the needle roller offers the longest bearing length together with the largest possible number of supporting rolling elements. The large number of linear contact points guarantees a significant load carrying capacity and rigidity. If the need for rigidity is not particularly important, the cylindrical roller provides a guidance system with greater elasticity. In this case, the high load carrying capacity which is characteristic of all these guidance systems is maintained.

Just as machine manufacturers automatically entrust specialised companies with the production of ball, roller or needle roller bearings, it is also advisable that they contact qualified specialists to produce linear guidance systems with rolling elements. EGIS, a medium-sized Swiss company, has been specialising for 50 years in the production of high-precision linear guidance systems which are essentially used in the following fields:

- Machine tool construction**
- Printing machines**
- Measurement technology**
- Automation**
- Robotics**
- Optics**
- Productronics**
- Medical technology**

In addition to a detailed technical section, this catalogue contains comprehensive information on the far-reaching EGIS programme for precision guideways in standard and made-to-measure lengths and the associated flat and angled flat cage assemblies as well as instructions relating to manufacturing possibilities for special parts to suit customers' requirements.

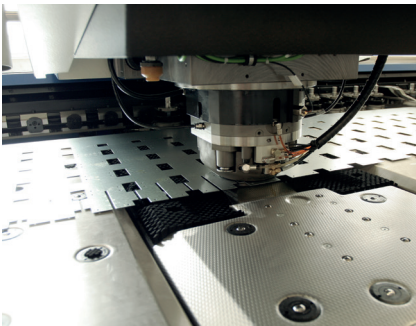

PRODUCT OVERVIEW

PRODUCT TECHNOLOGY

1 P.10-43

M AND V GUIDEWAYS

WITH NEEDLE OR CYLINDRICAL
ROLLER FLAT CAGE ASSEMBLY

2 P.44-47

M and V guideways are combined with angled flat cage assemblies and are particularly suitable for high load carrying capacities, rigidity, minimal friction and a high level of accuracy. They are used as linear locating bearings. They are manufactured in standard lengths up to a maximum of 1,000 mm which allows for rapid delivery.

In order to respond to specific customer requirements, the guideways in this range can also be supplied in made-to-measure lengths, i.e. in any required length up to the maximum length specified in the dimension table.

The guidance systems can be set to be free of clearance or can be preloaded to enhance rigidity using pressure screws.

ML GUIDEWAYS

WITH ADJUSTING GIB
FOR NEEDLE ROLLER FLAT CAGE ASSEMBLIES

3 P.48-51

This series combines an M guideway with an adjusting gib which distributes the preload equally over the entire length of the guidance system.

The pitch of the gib surface is 1.5%. ML guideways fulfil optimum requirements in terms of rigidity and precision.

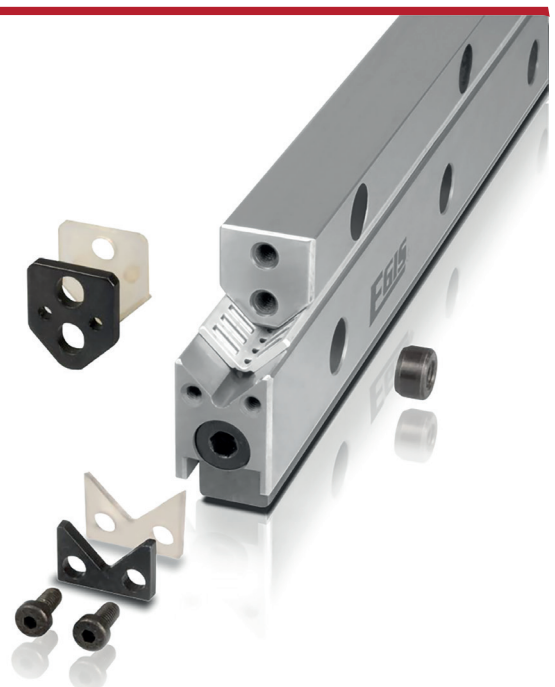
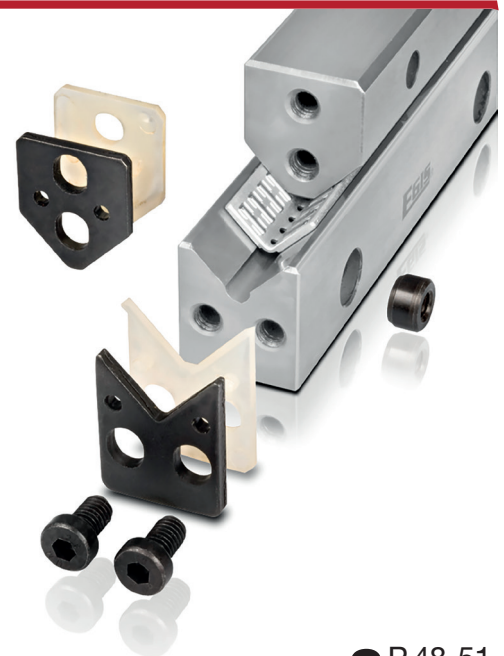

MVZ (M/V/ML) GUIDEWAYS
WITH INTEGRATED TOOTHED RACK
FOR POSITIVE CONTROL OF THE NEEDLE
ROLLER FLAT CAGE ASSEMBLY

4 P.52-55

In this series, the angled flat cage assembly is subjected to positive control by an integrated toothed wheel / toothed rack unit. This guarantees perfect movement for the flat cage assembly even under difficult operating conditions.

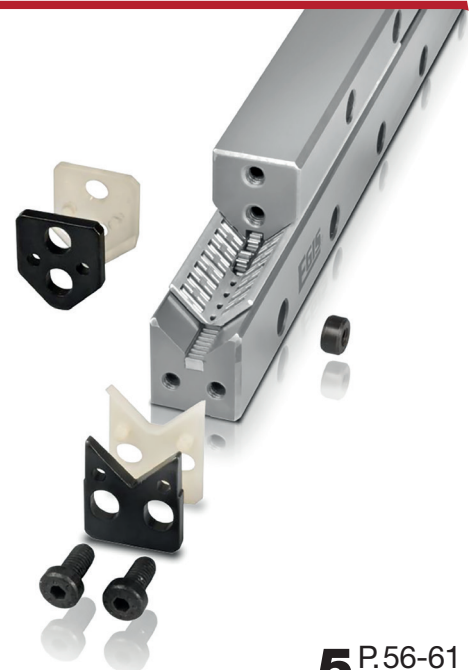

M AND ML GUIDEWAYS
WITH SLIDING LAYER

5 P.56-61

The guideways in this series consist of an unhardened guideway with a layer fixed by adhesive. They are combined with V guideways and possess the same mounting dimensions as the M/ML and V guideways with flat cage assemblies. They are used in particular when an increased level of friction is required to provide damping or when static or pulsating loads are involved.



S AND J GUIDEWAYS WITH NEEDLE ROLLER FLAT CAGE ASSEMBLY

6 P.62-67

These guideways are used in combination with needle roller flat cage assemblies as linear non-locating bearings. They are supplied in two versions, one of which possesses a flat structure and is therefore space-saving whilst the other has the same dimensions as the corresponding M and V guideways.



LUE COUNTERSTAY SYSTEM WITH NEEDLE ROLLER AND CYLINDRICAL ROLLER FLAT CAGE ASSEMBLIES

7 P.68-71

These units consist of a locating guidance system, a non-locating guidance system and an L counterstay which preloads the two guidance systems. This arrangement prevents the system from becoming distorted by thermal expansion.

The LUE counterstay system provides the highest level of precision of all linear guidance systems with rolling elements.

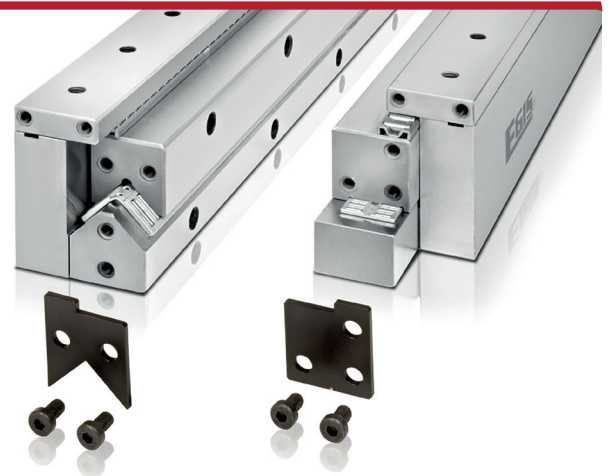

FLAT CAGE ASSEMBLIES

8 P.72-81

Flat cage assemblies consist of a basic cage made from plastic or metal and a large number of precisely guided rolling elements. Needle rollers provide a minimal construction height and optimum load carrying capacity and rigidity whilst cylindrical rollers are less demanding with regard to the connecting structure and have a slightly less rigidity. Balls create the lowest level of friction of all rolling bearings.

Flat cage assemblies are designed for use with precision guideways but can also be used directly with customer-specific elements with appropriate raceways.

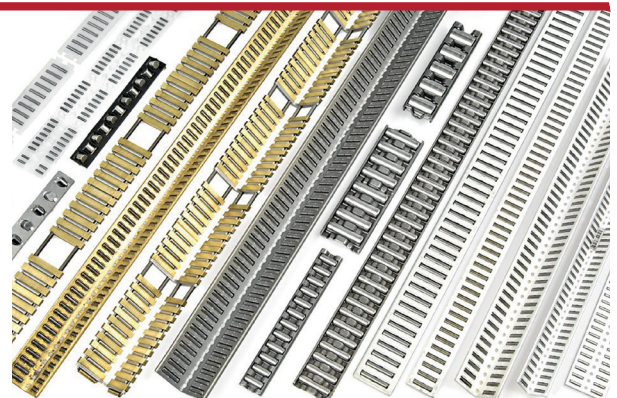

ACCESSORIES

END PIECES, WIPERS, INSERT NUTS

9 P.82-87

End pieces prevent the cage assembly from moving out of the loaded zone. Wipers protect the raceways against soiling under normal operating conditions.

Insert nuts allow for the transforming of a counterbore into a threaded hole.

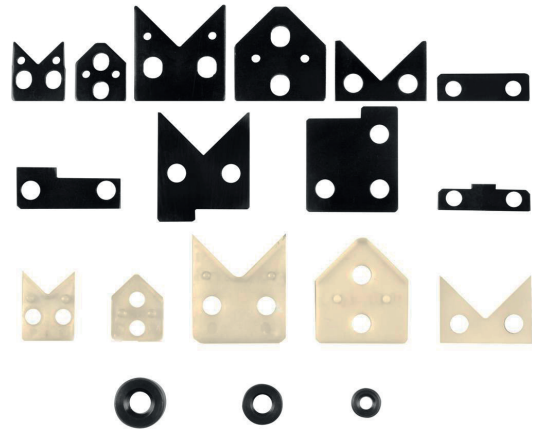
**ALTERNATIVE VERSIONS****10** P.88-89**SPECIAL DESIGNS****11** P.90-91

Guideways for cross roller and ball flat cage assemblies
 Guideways for hydrostatic guidance systems
 Guideways for air bearings
 Guideways with specific shapes and dimensions
 Linear recirculating roller bearings (RUSW and U-100)



TABLE OF CONTENTS

1	PRODUCT TECHNOLOGY	10
2	M AND V GUIDEWAYS WITH NEEDLE OR CYLINDRICAL ROLLER FLAT CAGE ASSEMBLY	44
3	ML GUIDEWAYS WITH ADJUSTING GIB AND V GUIDEWAYS WITH NEEDLE ROLLER FLAT CAGE ASSEMBLY	48
4	GUIDEWAYS WITH INTEGRATED TOOTHED RACK MVZ (M/V/ML) FOR POSITIVE CONTROL OF THE NEEDLE ROLLER FLAT CAGE ASSEMBLY	52
5	M AND ML GUIDEWAYS WITH SLIDING LAYER (TURCITE OR PERMAGLIDE)	56
6	S AND J GUIDEWAYS WITH NEEDLE ROLLER FLAT CAGE ASSEMBLY	62
7	LUE – COUNTERSTAY SYSTEM WITH NEEDLE AND CYLINDRICAL ROLLER FLAT CAGE ASSEMBLIES	68
8	FLAT CAGE ASSEMBLIES	72
9	ACCESSORIES END PIECES / WIPERS FOR GUIDEWAYS / ESM INSERT NUTS FOR GUIDEWAYS	82
10	ALTERNATIVE VERSIONS	88
11	SPECIAL DESIGNS	90

ORDER EXAMPLE

Example of how to place an order for rails and cages:

10 guides M4020x300-T15-Q10-E2-US
 10 guides V4020x500-T03-Q10-US
 10 cages E-HW15x300-AL-G2

Example of ordering a rail set:

Required for pairing when using different rail types in the same slide.
 The set is packaged in a single package.
 20 sets M/V/ML5025x300-Q6
 Composed of:

- 1 M5025x300-T15-Q6-2SX
- 1 ML6025x300-T15L-Q6-2SX
- 2 V5025x300-T15-Q6-US
- 2 E-HW16 x 226-AI-G2
- 4 EV5025

1.1	UNITS AND DEFINITIONS	10
1.2	PRECISION AND TOLERANCES	11
1.2.1	Qualities	11
1.2.2	Profile tolerances	11
1.2.3	Lengths, hole distances	11
1.2.4	Matching	12
1.2.5	Straightness	13
1.2.6	Rolling elements	13
1.3	APPLICATION FEATURES	14
1.3.1	Choice of arrangement type	14
1.3.2	Determination of guideway and cage lengths	15
1.3.3	Hole types and hole patterns	16
1.3.4	End pieces and wipers	18
1.3.5	Load rating, load carrying capacity	19
1.3.5.1	Basic static load rating	19
1.3.5.2	Static load carrying capacity	19
1.3.5.3	Basic dynamic load rating	20
1.3.5.4	Dynamic load carrying capacity and rating life	20
1.3.5.5	Effective load rating	22
1.3.5.6	Correction factors for load carrying capacity	23
1.3.5.7	Eccentric load	24
1.3.5.8	Calculation	25
1.4	RIGIDITY	30
1.5	PRELOAD	32
1.5.1	Setting the preload	32
1.5.1.1	Pressure screws	33
1.5.1.2	Guideways with adjusting gib	33
1.6	LUBRICATION	34
1.6.1	Lubricants	34
1.6.2	Lubricating with grease	34
1.6.2.1	Primary operation and grease quantity	34
1.6.2.2	Relubrication	35
1.6.3	Lubricating with oil	35
1.7	FRICTION	36
1.8	PROTECTION AGAINST SOILING	37
1.9	OPERATING LIMITS	37
1.9.1	Operating temperatures	37
1.9.2	Accelerations	37
1.9.3	speeds	37
1.10	INSTALLATION GUIDELINES	38
1.10.1	Precision of the connecting structure	38
1.10.2	Assembly instructions	39
1.10.2.1	Prior to installation	39
1.10.2.2	Closed layout	40
1.10.2.3	Open layout	41

1.1 UNITS AND DEFINITIONS

B	mm	Guideway width	L	mm	Guideway length
B1	mm	Cage width	L	10⁵m	Nominal rating life
b	mm	Distance between guidance system centres	L1	mm	Distance between the first hole and the start of the guideway
b1	mm	Distance between rear guideway surfaces	L1	mm	Distance between the first or last pocket centre and the end of the cage
C	N	Basic dynamic load rating for cage length of 100 mm	L2	mm	Distance between the last hole and the end of the guideway
C_w	N	Effective dynamic load rating	L1, L2_{min}	mm	Minimum value for L1 and L2
C_{we}	N	Corrected effective dynamic load rating	LA	mm	Hole distance in guideways
C_L	N/mm	Rigidity of the flat cage guidance system	LA	mm	Spacing distance in flat cages
C₀	N	Basic static load rating for cage length of 100 mm	L_h	h	Nominal rating life in operating hours
C_{0we}	N	Corrected effective static load rating	L_k	mm	Cage length
C_{0w}	N	Effective static load rating	L_R	mm	Guideway length with running surface for the wiper
D_w	mm	Ball diameter	n	-	Maximum possible number of hole distances LA
e	mm	Eccentricity of the load	n_{osz}	min⁻¹	Number of double strokes per minute
f_H	-	Dynamic hardness factor	p	-	Rating life exponent
f_{H0}	-	Static hardness factor	p	N/mm²	Contact pressure for sliding layer
f_α	-	Dynamic load direction factor	P	N	Dynamic equivalent load
f_{α0}	-	Static load direction factor	P₀	N	Static equivalent load
F	N	Operating load, guide loading	q_i	%	Proportion of total duration
F_i	N	Variable load	RS	N	Damping force in direction of movement
F_R	N	Displacement resistance	S₀	-	Static load safety factor
F_{R0}	N	F _R , lubricant friction percentage	t	mm	Depth of thread in T03 holes
F_{R1}	N	F _R , load-dependent rolling friction percentage	v_i	m/min	Variable speed
F_{RA}	N	Displacement resistance, wiper percentage	v̄	m/min	Dynamic equivalent speed
F_{RV}	N	Carriage displacement resistance, preloaded	x	-	Number of holes
F_w	N	Limiting load for effective cage length	Z	-	Number of rolling elements per row
H	mm	Distance from extreme stroke positions	α	°	Load direction angle deviating from main load direction
k_F	-	Dynamic load factor	δ	μm	Elastic deformation at contact points
k_{0F}	-	Static load factor	μ	-	Friction coefficient
K	-	Type factor for determination of rigidity	ν	mm²s⁻¹	Kinematic viscosity
			Δh	μm	Permissible height variation

1.2 PRECISION AND TOLERANCES

1.2.1 QUALITIES

The raceways and locating surfaces are precision-ground.

The guideways are supplied in 3 qualities (parallelism tolerance of the raceways to the reference sides of the guideway in relation to a defined length).

- Q10: normal quality for general machine construction
- Q6: precise quality for machine tool construction
- Q2: particularly precise quality for exceptionally demanding structures

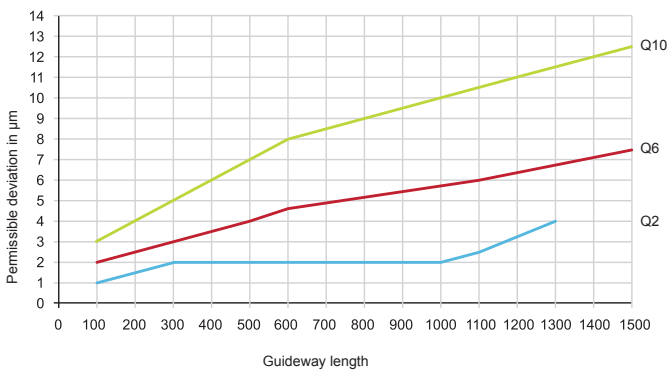

1.2.2 PROFILE TOLERANCES

See product chapter

1.2.3 LENGTHS, HOLE DISTANCES

Length: the length tolerance is defined using the formula $\pm [0.2+(0.0012 \cdot \text{length } L)]$.

Guideways which exceed the maximum length indicated (see “normal lengths” table) are manufactured in several sections. These sections are matched precisely. It is important not to interchange the guideways in order to maintain the tolerance during assembly.

Hole distances: the tolerance of the hole distances is calculated to ensure that guideways can be assembled on a pre-drilled hole pattern up to the maximum normal length. The tolerance is measured between the first and last guideway hole and is distributed evenly over the length.

For guideways which exceed the maximum normal length, the suffix “P” is required in order to maintain the corresponding tolerance.

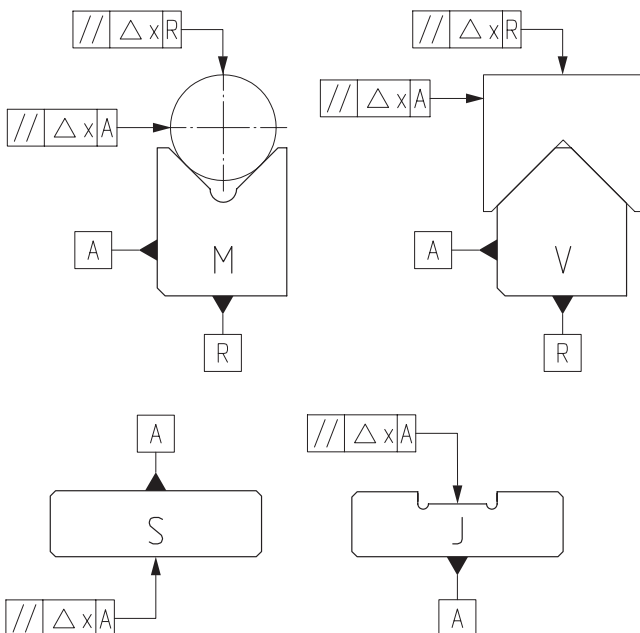

1.2.4 MATCHING

Guideways of the same design (same order reference) are manufactured, labelled and packed in pairs. Paired matching is based on the distance between the centre of the profile and the mounting surface "A".

Standard matching (US1/US2) allows parts to be exchanged whilst maintaining a very narrow tolerance. In the highest tolerance category or at the customer's request, the guideways are matched and labelled by more narrow tolerances.

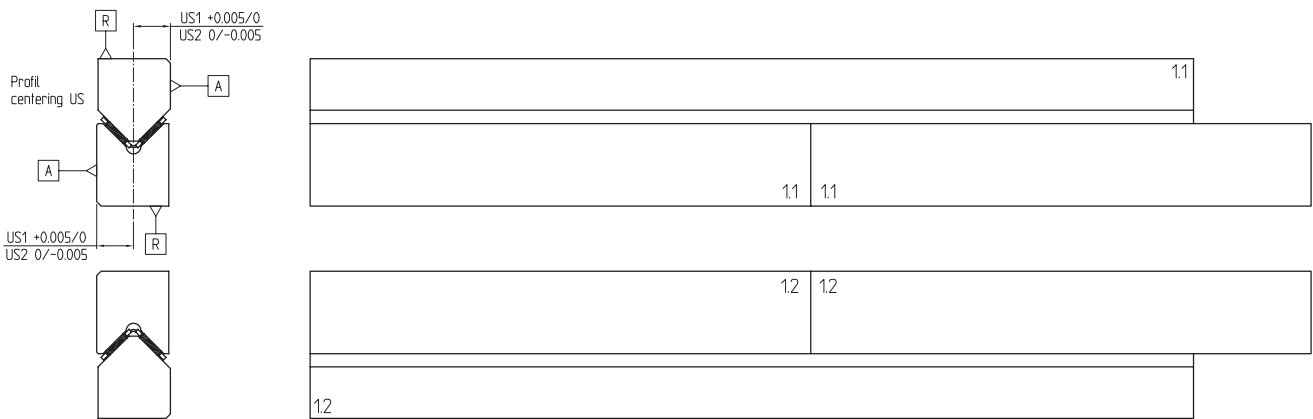

For guideways with different order references which still have to be matched in pairs, the suffix "X" has to be added to the order references, e.g.

- 1M + 1ML = 2SX or
- 1M + 1V + 1J + 1S = 4SRX or
- 1V...T15 + 1V...T03 = 2SX

Matching possibilities:

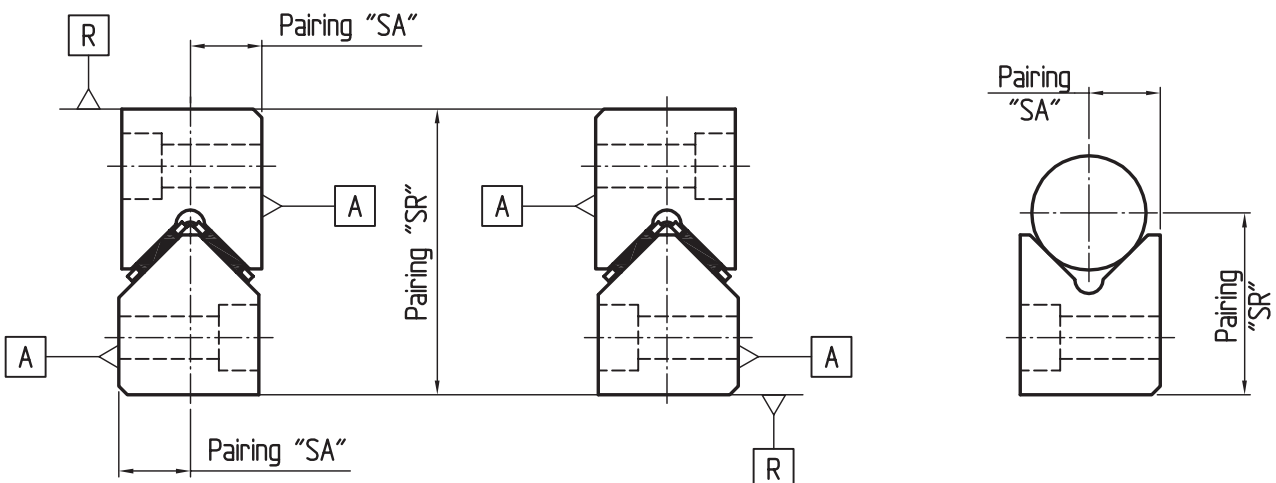

Paired matching code	Number of guideways matched together	In relation to reference side
2SA	2	Reference side A
3SA	3	Reference side A
4SA	4	Reference side A
etc...	Number of guideways	Reference side A
2SR	2	Reference side R
3SR	3	Reference side R
4SR	4	Reference side R
etc...	Number of guideways	Reference side R
2SAR	2	Reference sides A + R
3SAR	3	Reference sides A + R
4SAR	4	Reference sides A + R
etc...	Number of guideways	Reference sides A + R

1.2.5 STRAIGHTNESS

Straightness as well as parallelism is checked in the factory (tolerances according to DIN 644).

Straightness variances can be balanced out by tightening against the locating surface during assembly.

1.2.6 ROLLING ELEMENTS

Flat cage assemblies comprise needle or cylindrical rollers with a diameter tolerance of 2 µm and a geometrical accuracy of 1 µm.

For particularly challenging requirements, especially for guideways with a quality level of 2, specially designed needle or cylindrical rollers can be supplied with a diameter tolerance of 1 µm and a geometrical accuracy of 0.5 µm.

The diameter tolerance amounts to 1 µm and the geometrical accuracy 0.13 µm for ball bearings.

See table (page 74), in chapter 8 on flat cage assemblies.

1.3 APPLICATION FEATURES

1.3.1 CHOICE OF ARRANGEMENT TYPE

Closed layout M/V

This layout can carry loads and moments in any direction, can be adapted to any operating position and can be preloaded (preloading page 32).

It is a locating/locating bearing and consists of two M / ML and two V guideways with the corresponding angled flat cage assemblies.

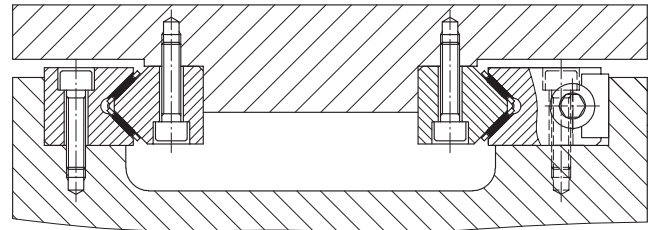

Figure 1. Closed layout M/V

Open layout

This layout is extremely assembly-friendly and is mainly used for applications with loads acting centrally or vertically.

It is a locating/non-locating bearing and consists of M and V guideways with the corresponding angled flat cage assembly and J and S guideways with the corresponding flat cage assembly.

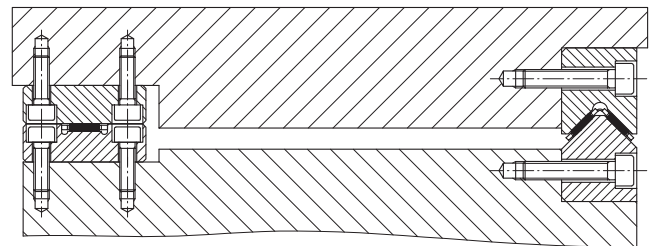

Figure 2. Open layout M/V, J/S

Closed layout LUE

This layout can carry loads and moments in any direction in response to the most demanding precision requirements. The system is preloaded by components which have been adjusted against one another in terms of dimensions.

The subdivision into locating and non-locating bearings prevents the system from becoming distorted by thermal expansion. The guidance system consists of M and V guideways, J and S guideways, LU counterstays, angled flat and flat cage assemblies.

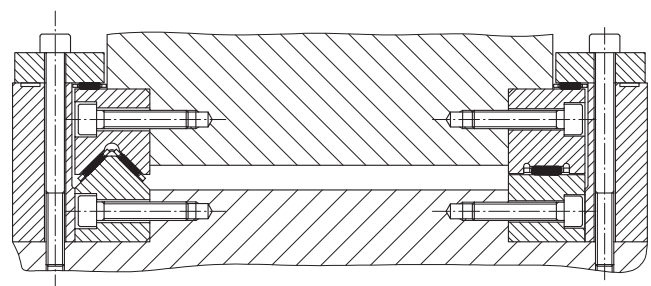

Figure 3. Closed layout LUE

1.3.2 DETERMINATION OF GUIDEWAY CAGE LENGTHS

The rigidity and load carrying capacity of the guidance system are determined by the size and length of the flat cage assembly (L_K). The load bearing capacity and load carrying capacity increase for moments along the longitudinal axis (rolling) in proportion to the cage length whilst the permissible moments along the vertical axis (yawing) and the diagonal axis (pitching) increase in square with the cage length.

Layout principles:

- The cage assembly always travels half of the stroke of the moving guideway
- The entire length of the cage assembly must always remain between the two guideways
- Wipers must always remain on the raceways

Recommendations for minimum cage lengths dependent on the stroke:

- $L_K \geq 1.5 \cdot H$ for open layout in order to maintain the operation limit (figure 12, page 24)
- $L_K \geq H$ for closed layout

H mm | distance from extreme stroke positions

A) Calculation of guideway lengths L, L_R

With preset cage length and stroke:

Guidance systems without wipers

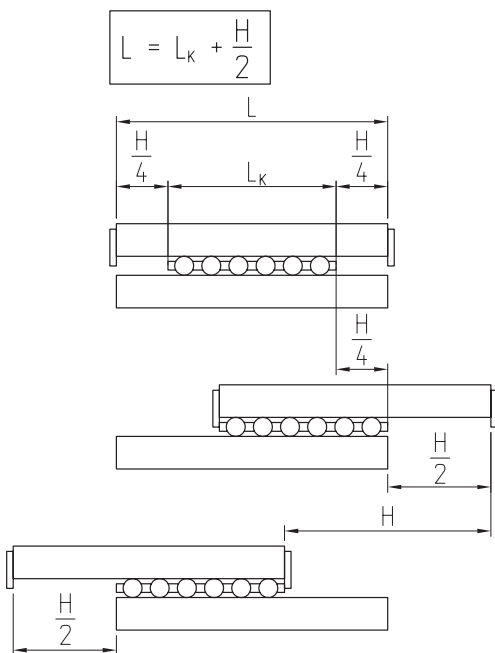

Guidance systems with wipers

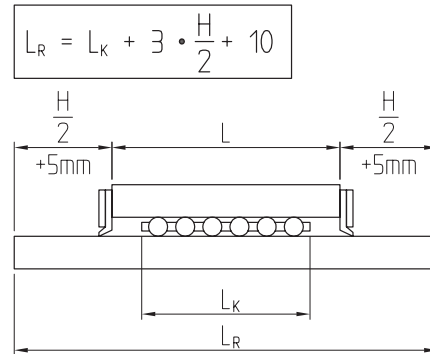

B) Calculation of cage length L_K

With preset guideway lengths and stroke:

Guidance systems without wipers

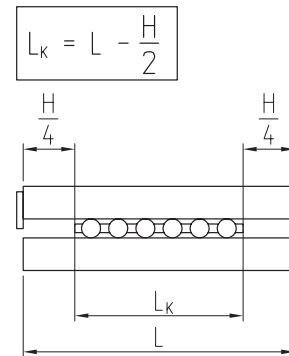

Guidance systems with wipers:

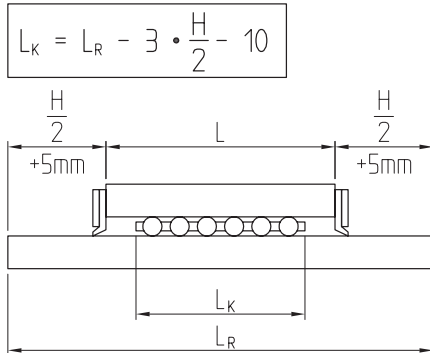

The necessary cage size can be selected on the basis of load and rigidity parameters.

Special length ratios:

If the lengths are configured according to the equations above, the flat cage assembly will be in every stroke position between the raceways.

In order to achieve the maximum load carrying capacity or a significant stroke, the lengths can be configured under normal operating conditions in such a way that the flat cage assembly extends beyond the ends of the guideways. Raceway lead areas should be provided in this case (suffix E2).

1.3.3 HOLE TYPES AND HOLE PATTERNS

Guideways are attached with screws. EGIS guideways are supplied with 5 hole types (figure 4).

EGIS guideways of standard lengths in the M and V ranges are hardened and pre-ground with T15 sink holes. By adding ESM insert nuts, these guideways can be attached in the same manner as with a threaded hole (T03, figure 5).

The insert nuts must be ordered separately and stuck into the counterbores (T13, accessories, page 87).

The guide rails can be supplied with smooth holes T10 or threaded holes T03.

Some guide rails can be supplied with hole type T1503, which allows the rail to be fastened on both sides. Either as T15 or as T03 or T13.

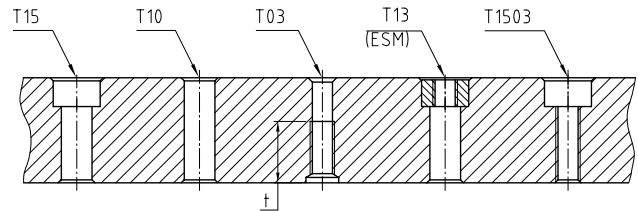

Figure 4. Hole types

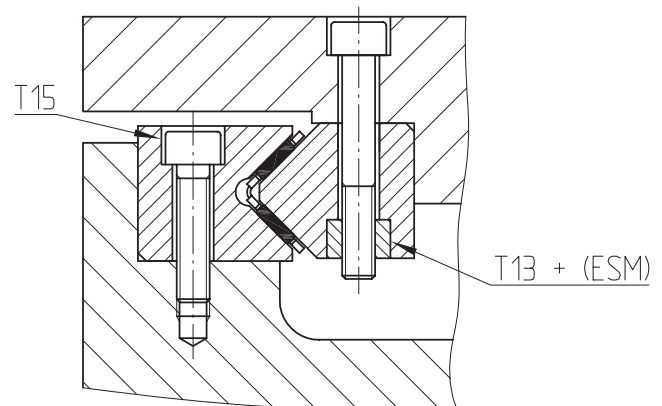

Figure 5. Attachment with hole type T13

With no particular specifications, the hole distances L1 and L2 at both ends of the guideways are of the same size and dependent on the guideway length (symmetrical hole pattern, figure 6).
 Guideways with non-symmetrical hole patterns may also be supplied on request.
 In this case the following values must apply: $L1 \geq L1_{min}$ and $L2 \geq L2_{min}$.

△ Particular attention should be paid to the position of the L1 distance. For the definition of the position of L1 see figure 7.
 Suffix LA (L1/L2)

Determining the hole patterns

Number of spacing distances

$$n = \frac{(L - 2 \cdot L1_{min})}{LA} \text{ whole number}$$

Distances L1 and L2

$$L1 + L2 = L - n \cdot LA$$

Guideways with symmetrical hole pattern

$$L1 = L2 = (L - n \cdot LA) / 2$$

Number of holes

$$x = n + 1$$

L	mm	Length of guideway
LA	mm	Hole distance
L1, L2	mm	Distance between the start or end of the guideway and the next hole
L1_{min}, L2_{min}	mm	Minimum value for L1 and L2 (Tables dimensions)
n	-	Maximum possible spacing distances
x	-	Number of holes

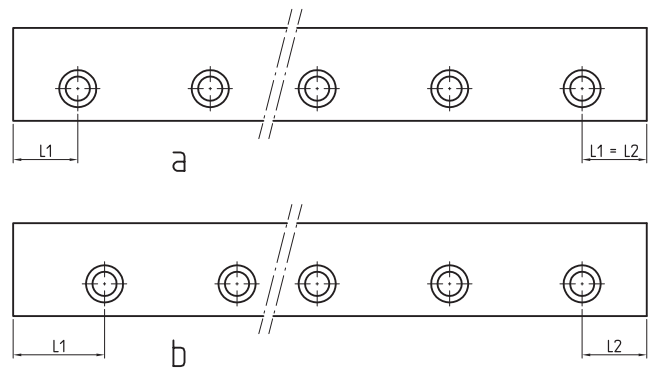

Figure 6. Symmetrical (a) and non-symmetrical (b) hole pattern with a series of holes

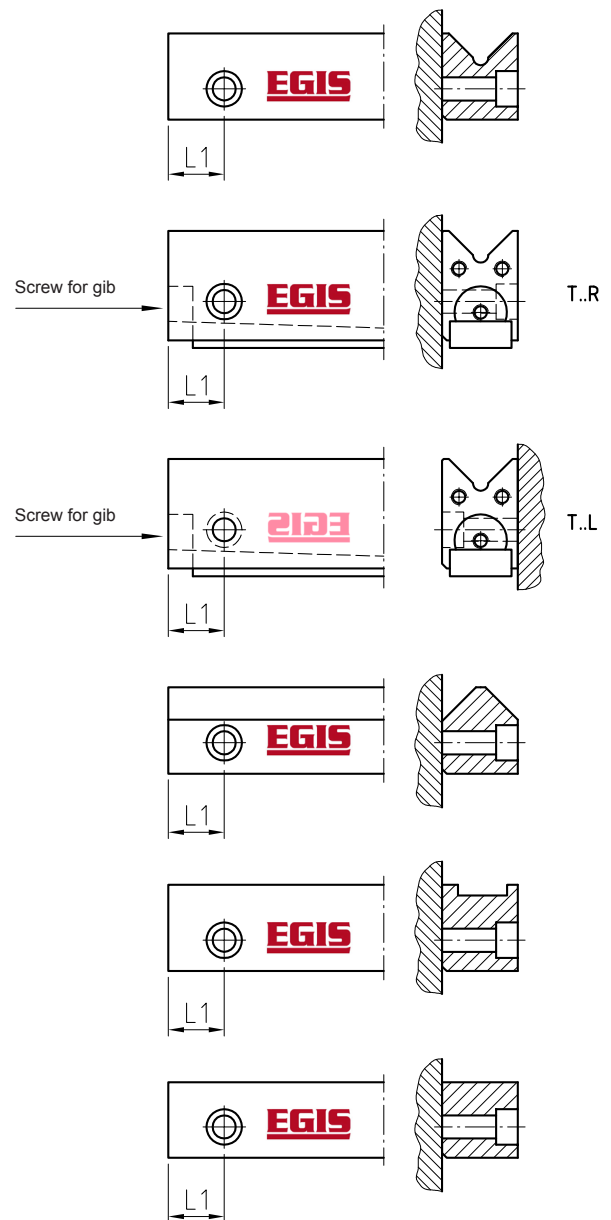

Figure 7. Position of distance between first hole and beginning of guideway L1

1.3.4 END PIECES AND WIPERS

End pieces or end pieces with wipers hold the cage assembly in place correctly in the final stroke positions. Two end pieces need to be mounted for each cage. If this is not possible, parts of the connecting structure should be used to assume the function of the end pieces.

- △ End pieces or wipers must not be used to limit the stroke.
- △ End pieces or wipers must not be allowed to cross over (figure 8)

In specific application scenarios, e.g. with rapid accelerations, extreme loads in the final stroke positions or in the case of alternating partial stroke which nevertheless remain constant over long periods, the cage positioning may no longer be guaranteed with normal end pieces. In such cases, it is possible when wipers are used to assemble additional end pieces before the wipers or to subject the cage to positive control by an integrated gear/toothed rack unit as an optimum solution (MVZ series, page 52).

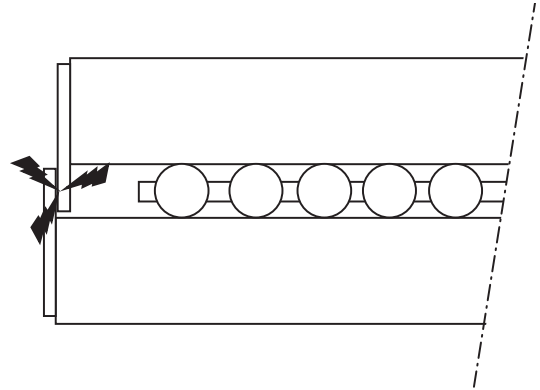

Figure 8. Incorrectly assembled end pieces or wipers

1.3.5 LOAD RATING, LOAD CARRYING CAPACITY

The dynamic and static load ratings are used as a reference for the layout of a flat cage guidance system. The load ratings for linear guidance systems without recirculating rolling elements are defined according to the ISO 14728 international standard.

1.3.5.1 BASIC STATIC LOAD RATING

The basic static load ratings C_0 are the loads which bring a permanent deformation of the raceways and rolling elements in a ten thousandth of the rolling element diameter.

Static load safety factor

The static load safety factor S_0 is the security in relation to the permanent deformation in the rolling contact.

$$S_0 = \frac{C_{0w}}{P_0}$$

S_0		Static load safety factor
C_{0w}	N	Effective static load rating (page 22)
P_0	N	Maximum static equivalent load

△ Particular attention should be paid to the load safety factor.

According to ISO 14728, the static safety $S_0 = C_0/P_0$ must not fall below the value of 2.

If strict requirements apply in terms of the running accuracy and smoothness, the static load safety factor should not fall below $S_0 = 3$.

1.3.5.2 STATIC LOAD CARRYING CAPACITY

The permissible static load for a flat case guidance system is limited by the following characteristics:

- Basic static load rating of the flat cage assemblies: recommendations for S_0 should be observed.
- Load carrying capacity of the raceways: required hardness HRC 58 min.
- Load carrying capacity of the connecting structure: the connecting structure is generally configured with a high degree of rigidity and therefore sufficient strength.
- Load carrying capacity of the screw connection: the layout of the guideway attachment is based on the screw strength 8.8 and the corresponding tightening torque taking the standard materials for the connecting structure into account. Screws of this level of strength allow for the transferral of loads whilst scarcely affecting the precision of the guidance system.

When screws of a higher strength category are used, the tightening torque according to the strength category 8.8 should not be exceeded in the interest of accuracy (exception: LUE system counterstay, see page 71).

△ It is important to check the screw connection where $S_0 < 3$ when tensile and / or moment loads are predominant.

LOAD RATING, LOAD CARRYING CAPACITY

1.3.5.3 BASIC DYNAMIC LOAD RATING

The basis for the basic dynamic load rating C is the nominal rating life of 100,000 m displacement distance obtained or exceeded with a reliability of 90%.

1.3.5.4 DYNAMIC LOAD CARRYING CAPACITY AND RATING LIFE

The dynamic load carrying capacity is determined by the fatigue behaviour of the bearing components. The fatigue period (the rating life in hours) is obtained from the load and the movement speed of the guidance system as well as the statistical probability of damage occurring.

Nominal rating life

$$L = \left(\frac{C_w}{P} \right)^p$$

$$L_h = \frac{8.33 \cdot 10^5}{H \cdot n_{osz}} \cdot \left(\frac{C_w}{P} \right)^p$$

$$L_h = \frac{1666}{\bar{v}} \cdot \left(\frac{C_w}{P} \right)^p$$

L	10⁵m	Nominal rating life
L_h	h	Nominal rating life in operating hours
C_w	N	Effective dynamic load rating (p. 24)
P	N	Dynamic equivalent load
p	-	Rating life exponent

For flat cage guidance systems with rollers: $p=10/3$
 For flat cage guidance systems with balls: $p=3$

H	mm	Distance from extreme stroke positions
n_{osz}	min⁻¹	Number of double strokes per minute
\bar{v}	m/min	Dynamic equivalent speed

△ According to ISO 14728, the dynamic equivalent load must not exceed the value $P = 0.5 \cdot C_w$.

LOAD RATING, LOAD CARRYING CAPACITY

Equivalent load and speed

The life calculation equation requires a constant load and speed. If this is not the case, equivalent operating values may be used for the calculation. (ISO 281 standard)

General dynamic equivalent load

$$P = \sqrt[p]{\left(\int_0^T |v(t) \cdot F^p(t)| dt\right) / \left(\int_0^T |v(t)| dt\right)}$$

General dynamic equivalent speed

$$\bar{v} = \frac{1}{T} \int_0^T |v(t)| dt$$

Gradually alternating load

$$P = \sqrt[p]{\frac{q_1 \cdot F_1^p + q_2 \cdot F_2^p + \dots + q_z \cdot F_z^p}{100}}$$

Gradually alternating speed

$$\bar{v} = \frac{q_1 \cdot v_1 + q_2 \cdot v_2 + \dots + q_z \cdot v_z}{100}$$

Gradually alternating load and gradually alternating speed

$$P = \sqrt[p]{\frac{q_1 \cdot v_1 + F_1^p \cdot q_2 \cdot v_2 \cdot F_2^p + \dots + q_z \cdot v_z \cdot F_z^p}{q_1 \cdot v_1 + q_2 \cdot v_2 + \dots + q_z \cdot v_z}}$$

P	N	Dynamic equivalent load
p	-	Rating life exponent:

For flat cage guidance systems with rollers: p=10/3
 For flat cage guidance systems with balls: p=3

q_i	%	Proportion of total duration
F_i	N	Variable load
v_i	m/min	Variable speed
\bar{v}	m/min	Dynamic equivalent speed

Operating life

The operating life is the actual expected rating life of a flat cage guidance system. It may differ from the nominal rating life.

Potential causes include wear and tear and/or fatigue due to:

- Soiling
- Insufficient lubrication
- Misalignment
- Movements with minimal strokes
- Vibrations during dead time (false brinelling).

The operating life of a flat cage guidance system cannot be calculated precisely in advance due to the wide range of installation and operating conditions. The most reliable information is obtained from comparisons with similar installations.

1.3.5.5 EFFECTIVE LOAD RATING

The basic dynamic and static load ratings C and C_0 given for the different products relate to a cage with a theoretical length of 100 mm. This allows direct comparisons to be made between the load carrying capacities of flat cages of different series and dimensions. The effective dynamic and static load ratings C_w and C_{0w} are calculated according to the following equations for the effective cage lengths.

For needle roller flat cage assemblies:

$$C_w = C \cdot \left(\frac{L_k - 2L1 + LA}{100} \right)^{\frac{3}{4}} \cdot \left(\frac{L_k - 2L1}{100 - LA} \right)^{\frac{1}{36}}$$

$$C_{0w} = C_0 \cdot \left(\frac{L_k - 2L1 + LA}{100} \right)$$

For ball flat cage assemblies:

$$C_w = C \cdot \left(\frac{L_k - 2L1 + LA}{100} \right)^{\frac{2}{3}} \cdot \left(\frac{L_k - 2L1}{100 - LA} \right)^{\frac{1}{36}}$$

$$C_{0w} = C_0 \cdot \left(\frac{L_k - 2L1 + LA}{100} \right)$$

C	N	Basic dynamic load rating for a cage length of 100 mm (table dimensions)
C₀	N	Basic static load rating for a cage length of 100 mm (table dimensions)
C_w	N	Effective dynamic load rating
C_{0w}	N	Effective static load rating
L_k	mm	Cage length (figure 9)
L1	mm	Distance between the first and last pocket centre and the end of the cage (figure 9)
LA	mm	Spacing distance in the flat cage (figure 9, table dimensions)

The values for C_{0w} and C_w correspond to the load rating calculation according to ISO 14728

△ The equations only provide precise results when the cage length L_k is based on a whole number of rolling elements per row.

Equation for verification of Z :

$$Z = \frac{L_k - 2L1}{LA} + 1 = \text{whole number}$$

Z - number of rolling elements per row (figure 9)

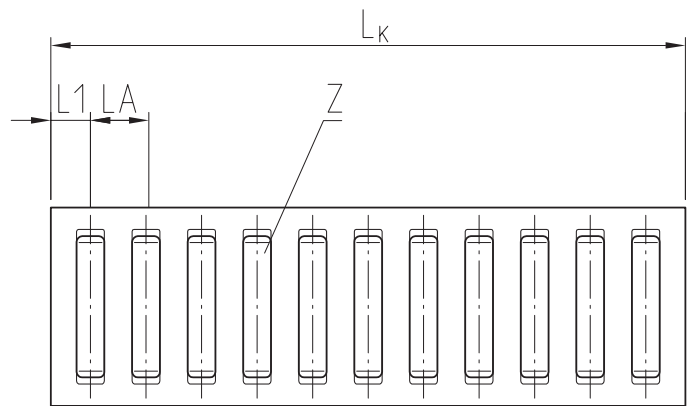

Figure 9. Dimensions to determine the effective load rating

1.3.5.6 CORRECTION FACTORS FOR LOAD CARRYING CAPACITY

The basic load ratings given for the different products only apply subject to the following requirements:

- Raceway hardness \geq HRC 58 (670HV)
- Centric load direction

Deviating conditions are to be taken into account using the following correction factors:

- Hardness factors f_{H0} or f_H

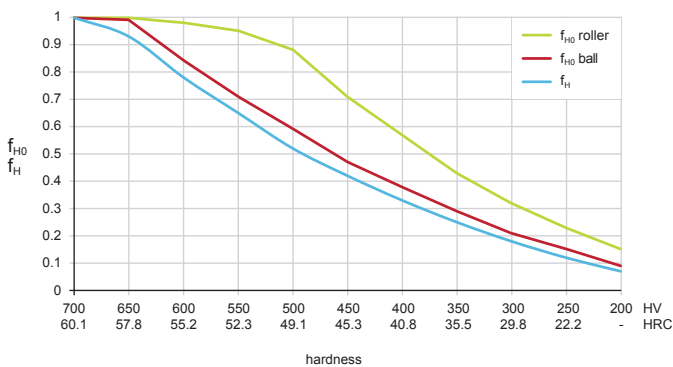

Figure 10. Hardness factors

- Load direction factor f_α or $f_{\alpha0}$

The basic load ratings for the different products only apply provided that the load operates in symmetry with the cage shanks ($\alpha = 0^\circ$). The correction factor for other load directions can be obtained from the figure:

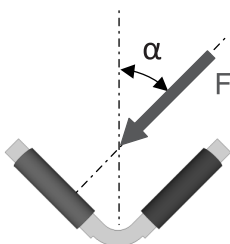
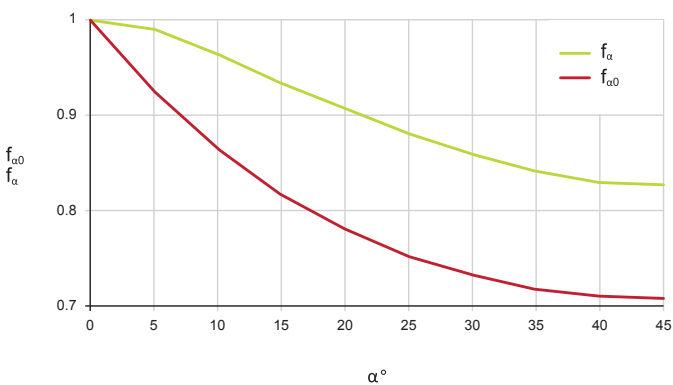

Figure 11. Load direction factor

Static load rating

$$C_{0we} = f_{\alpha0} \cdot f_{H0} \cdot C_{0w}$$

C_{0we}	N	Corrected effective static load rating
$f_{\alpha0}$	-	Static load direction factor
f_{H0}	-	Static hardness factor
C_{0w}	N	Static load rating for the effective cage length

Dynamic load rating

$$C_{we} = f_\alpha \cdot f_H \cdot C_w$$

C_{we}	N	Corrected effective dynamic load rating
f_α	-	Dynamic load direction factor
f_H	-	Dynamic hardness factor
C_w	N	Dynamic load rating for the effective cage length

1.3.5.7 ECCENTRIC LOAD

In a linear guidance system without recirculating rolling elements, the flat cage always travels half the stroke of the mobile guideway and thus alters its position in relation to the load. It therefore does not generally carry an equal load. However, the load ratings given for the different products only apply with an equal load distribution.

Eccentric load with open layout

Open layout: see application features (page 14, figure 2)
 In the case of an eccentric load, the load carrying capacity can be determined with the static equivalent cage load (figure 12).

$$P_0 = k_{0F} \cdot F$$

P₀	N	Static equivalent load
k_{0F}	-	Static load factor
F	N	Guide loading

Eccentric load with closed layout

Closed layout: see application features, (page 14, figure 1)

Linear guidance systems with a closed layout can carry additional loads and tilting moments. In these cases, the calculation of the equivalent cage load is fairly complex. EGIS offers support with corresponding calculation programmes on request (pages 26 to 31).

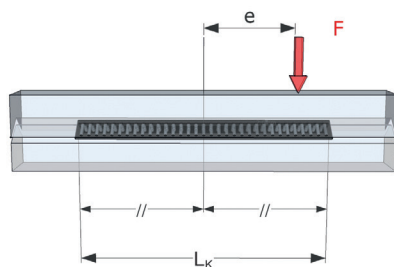
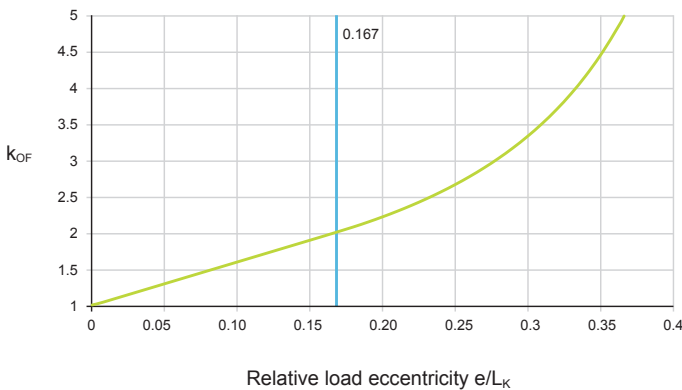

Figure 12. Static load factor for eccentrically loaded flat cages and open layout

△ If a load eccentricity of > 0.167 is exceeded, only part of the rolling element is loaded. This is extremely detrimental to the load carrying capacity and rigidity of the guidance system.

1.3.5.8 CALCULATION

Example

Input data

Guideways	M 5025 and V 5025
Flat cage assembly	E-HW15
Basic dynamic load rating for a cage length of 100 mm	$C = 25960 \text{ N}$
Basic static load rating for a cage length of 100 mm	$C_0 = 88900 \text{ N}$
Operating load, functioning centrally on the guidance system (factors $f_\alpha, f_{\alpha 0}, k_{0F} = 1$)	$F = 9500 \text{ N}$
Dynamic equivalent load	$P = 9500 \text{ N}$
Static equivalent load	$P_0 = 9500 \text{ N}$
Distance from extreme stroke positions	$H = 100 \text{ mm}$
Number of double strokes per minute	$n_{osz} = 50 \text{ min}^{-1}$
Cage length	$L_K = 300 \text{ mm}$

Required data

Static load safety factor	S_0
Nominal rating life	L and L_h

Calculation

Verification of number of rolling elements per row (LA, L1, dimension tables)

$$Z = \left(\frac{L_K - 2L1}{LA} \right) + 1 \quad Z = \left(\frac{300 - 7}{4.5} \right) + 1 = 66$$

For calculation:

$$L_K = (Z - 1) \cdot LA + 2L1 = 299.5 \text{ mm}$$

Effective static load rating

$$C_{0w} = C_0 \cdot \frac{L_K - 2L1 + LA}{100}$$

$$C_{0w} = 88900 \cdot \frac{297}{100} = 264000 \text{ N}$$

Static load safety factor S_0

$$S_0 = \frac{C_{0w}}{P_0} \quad S_0 = \frac{264000}{9500} = 27.8$$

Effective dynamic load rating C_w :

$$C_w = C \cdot \left(\frac{L_K - 2L1 + LA}{100} \right)^{3/4} \cdot \left(\frac{L_K - 2L1}{100 - LA} \right)^{1/36}$$

$$C_w = 25960 \cdot \left(\frac{295}{100} \right)^{3/4} \cdot \left(\frac{288}{95.5} \right)^{1/36} = 60250 \text{ N}$$

Nominal rating life L:

$$L = \left(\frac{C_w}{P} \right)^{10/3} \quad L = \left(\frac{60250}{9500} \right)^{10/3} = 472 \cdot 10^5$$

Nominal rating life L_h

$$L_h = \frac{8.33 \cdot 10^5}{H \cdot n_{osz}} \cdot \left(\frac{C_w}{P} \right)^{10/3}$$

$$L_h = \frac{8.33 \cdot 10^5}{100 \cdot 50} \cdot 472 = 78600 \text{ h}$$

Calculation programme

The calculation on pages 19 to 25 can be used to establish an initial layout for flat cage guidance systems. The equations are based on a defined static system. In practice, however, an undefined static system is generally used. This does not allow for simple calculations; in order to obtain a precise calculation, the preload and internal load distribution have to be taken into account. The load carrying capacity and rigidity for different loads can be calculated using a corresponding Excel help file egis.

Our Excel help file egis determines the following data:

- Static load safety factor
- Displacement stemming from the elasticity of the bearing.

The non-linear deflection of the rolling elements is taken into account in this context.

The connecting structure is assumed to be rigid.

The following details are required for the calculation of every load scenario (figure 14 and datasheet, page 27):

- Size and position of the elements of the guidance system
- Position of the drive axis
- Position of the loading point and external load components
- Shear-free moments
- Position of the balance points and size of weights
- Kinetic valves
- Duration of particular steps

The geometry and loads can be described simply using the following datasheet.

A right-handed coordinate system is used for the description. The right-hand rule applies for moments.

Position of co-ordinate origin:

- Carriages in central stroke position
- x: centre of bearing cage length
- y: centre plane of guideways
- z: central between the guideways

One or more stroke positions deviating from the central position may be used for the calculation.

The data entered in the datasheet correspond to the guidance system presented in figure 15 as an example.

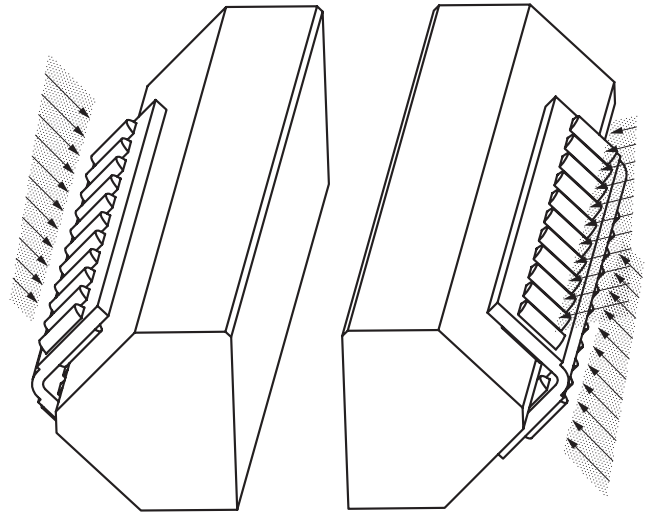

Figure 13. Internal load distribution in the case of loads produced by loads and moments

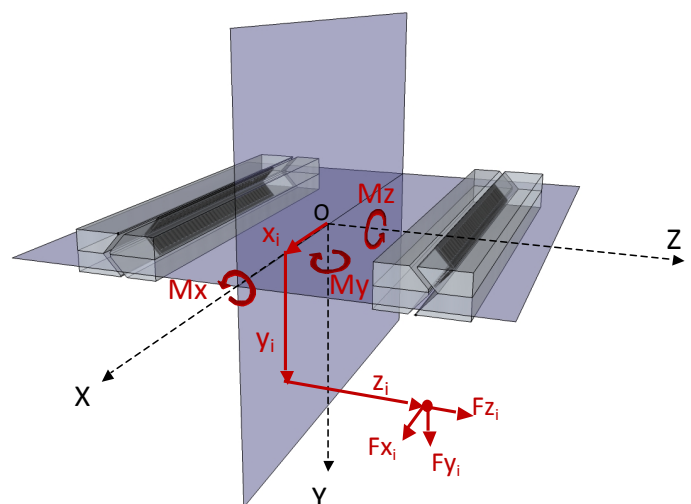

Figure 14. Coordinate system

Example: horizontal drilling carriage

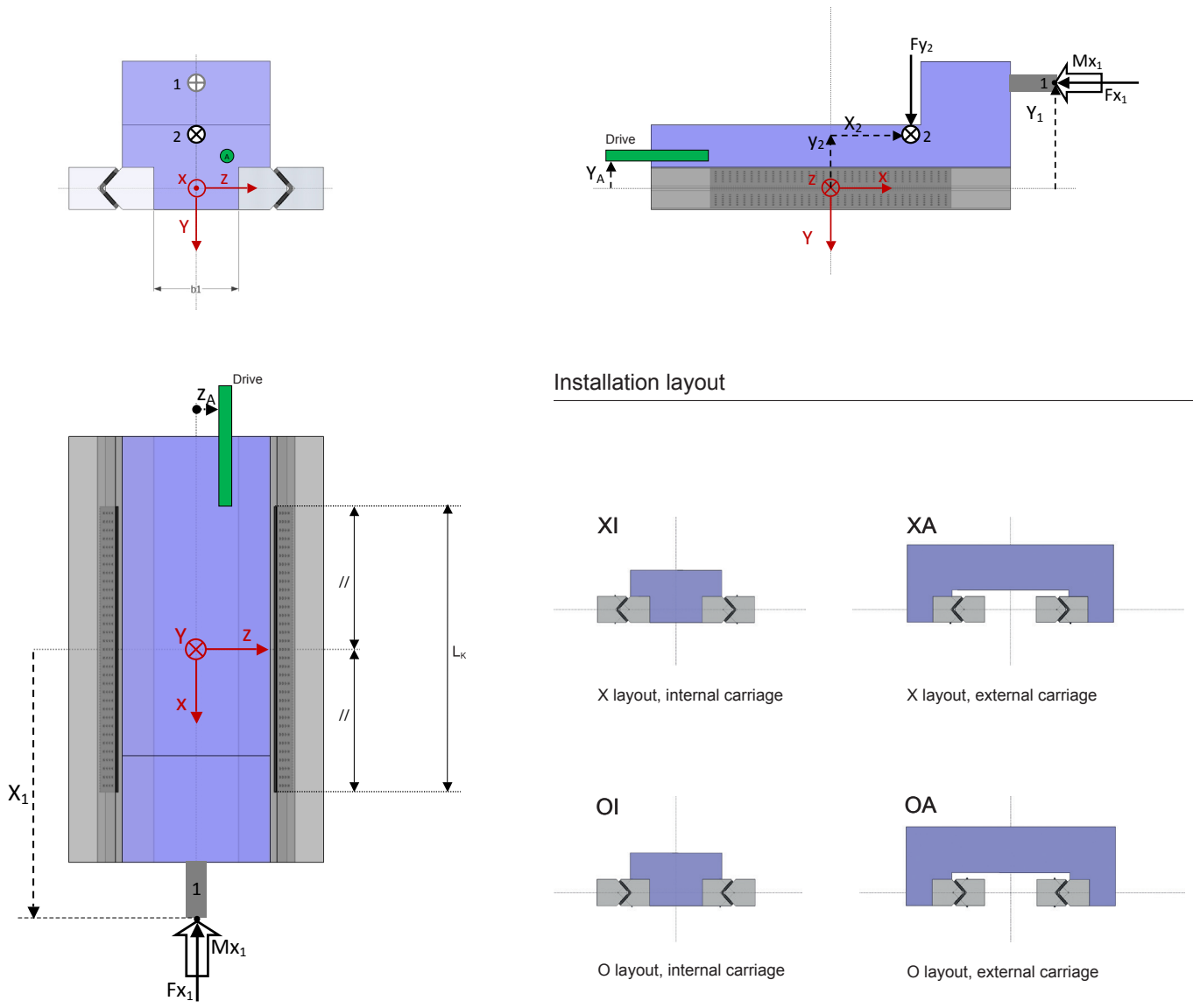

Figure 15. Geometry and load details

Example: horizontal drilling carriage

Results

Power on carriage drive
 Resulting load on guidance system:

F_x = -1200 N
F_y = 800 N
F_z = 0 N
M_x = -20000 Nmm
M_y = -36000 Nmm
M_z = -82400 Nmm

Required preload power **P_v** = 3050 N

Percentage rate of static load carrying capacity **C₀**: 2.54 %

Displacement of the guidance system:

del y = 0.13992 μm
del z = -0.00719 μm
phi x = -0.00152 mrad
phi y = -0.00389 mrad
phi z = -0.00863 mrad

Static load safety factor: **S₀** = 31.6

Displacement at point i (μm)

Nr.	del ix	del iy	del iz
1	-0.27622	0.18561	0.04155
2	-0.77686	-1.54327	0.88915
3	-0.34527	-0.33483	0.26788

The calculated displacements only include the effect of the deflection of rolling elements and raceways. The deformation of the connecting structure is not taken into account.

1.4 RIGIDITY

Flat cage guidance systems use needle rollers, cylindrical rollers or balls as load-bearing rolling elements. Needle rollers and cylindrical rollers possess a line contact in the rolling contact whilst balls possess a point contact. The operating load F creates an elastic deformation at the contact points and therefore causes the raceways to converge around the deflection δ .

Guidance systems with needle rollers are significantly more rigid than those with cylindrical rollers given the same space requirement due to the large number of contact lines. The rigidity of guidance systems with balls is considerably lower on account of the point contact (figure 16).

Rigidity is the relationship between the load and deformation:

$$C_L = \frac{F}{\delta}$$

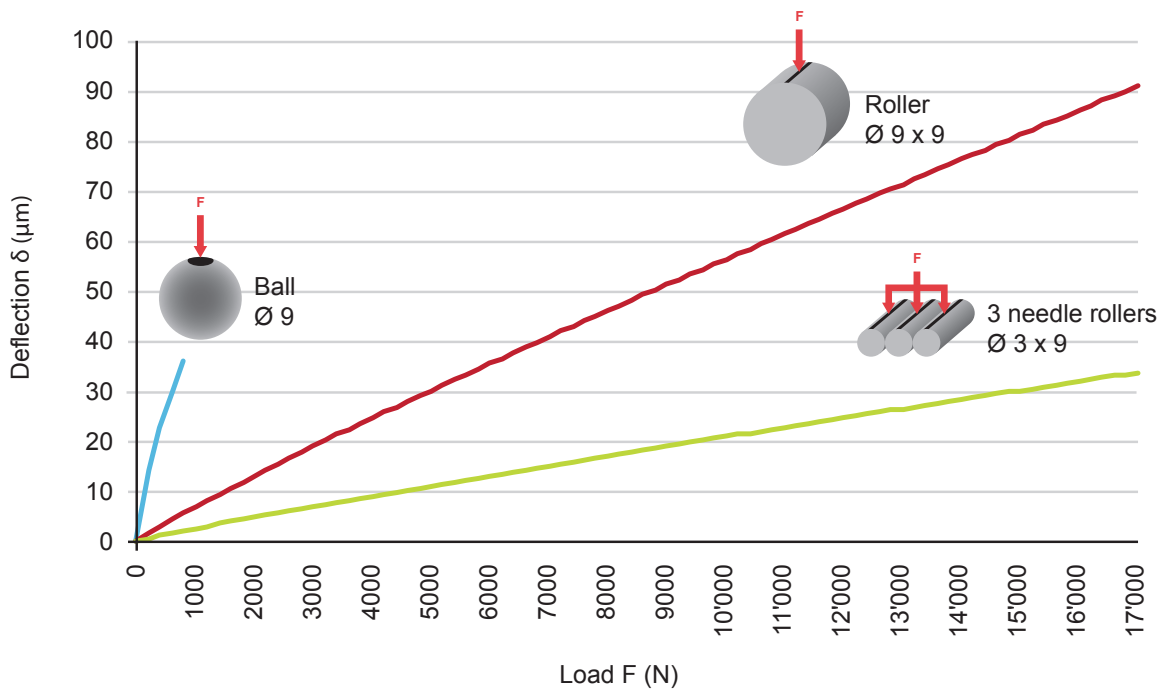

Figure 16. Comparison between rolling element types with the same space requirement

△ Deformations of the connecting structure, settlement phenomena, etc. are not taken into account. Deformation can therefore be more significant in practice.

In guidance systems with M and V guideways in a closed layout, the rigidity can be increased by pre-loading (preloading, page 32).

The rigidity is dependent on the load and the number and geometry of the rolling elements.

Flat cage guidance systems with line contact

$$\delta = K \cdot (F/Z)^{0.9} / L_w^{0.8}$$

$$C_L = 1/K \cdot F^{0.1} \cdot Z^{0.9} \cdot L_w^{0.8}$$

Flat cage guidance systems with point contact

$$\delta = K \cdot (F/Z)^{2/3} / D_w^{1/3}$$

$$C_L = 1/K \cdot F^{1/3} \cdot Z^{2/3} \cdot D_w^{1/3}$$

δ	μm	Elastic deformation at the contact points, convergence of the two raceway levels
K	-	Factor for the determination of elastic deformation dependent of the type (table 17)
F	N	Operating load
Z	-	Number of rolling elements per row
L_w	mm	Rolling element length
C_L	N/μm	Rigidity of the flat cage guidance system
D_w	mm	Ball diameter.

Calculation example

Guideway	M 5025 and V 5025
Flat cage assembly	E-HW15 x 300
Operating load	F = 9500 N
Number of rolling elements per row	Z = 66
Rolling element length	L _w = 6.8 mm
Type factor (table)	K = 0.0822

Elastic deformation calculation:

$$\delta = K \cdot (F/Z)^{0.9} / L_w^{0.8}$$

$$\delta = 0.0822 \cdot (9500/66)^{0.9} / 6.8^{0.8} = 1.6 \mu\text{m}$$

Rigidity calculation:

$$C_L = 1/K \cdot F^{0.1} \cdot Z^{0.9} \cdot L_w^{0.8}$$

$$C_L = 1/0.0822 \cdot 9500^{0.1} \cdot 66^{0.9} \cdot 6.8^{0.8} = 6100 \text{ N/}\mu\text{m}$$

Table 17: factor K for the determination of elastic deformation

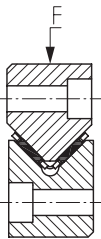
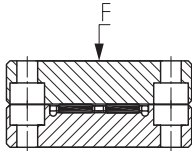
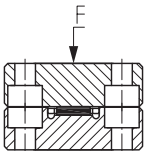
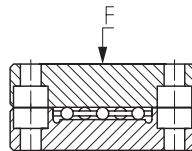
Guideway Type	Factor K	Guideway Type	Factor K
	0.0822		0.0426
	0.0794		0.8776

1.5 PRELOAD

The preload of flat cage guidance systems can be useful for the following reasons:

- Increase of rigidity
- Improvement of running accuracy
- Improvement of load distribution and reduction of maximum load on the outer rolling elements
- Increase of permissible moments

The preload influences the displacement resistance and rating life.

Reference value for the preload: 2 to 3% of C_0 .
The optimum preload for concrete load datas can be determined using our Excel help file egis.

An optimum preload reduces the possibility of uncontrolled movement in the flat cage assembly (cage roaming).

In order to guarantee that the rigidity of our linear guidance systems is fully optimised, care must be taken to ensure that the connecting structure is sufficiently rigid and precise.

In the case of imprecise connecting structures or ones which can be easily deformed, angle errors may occur between the raceways which create an increased load at the ends of the rolling elements.

This would not result in increased rigidity but rather the end load would reduce the operating life.

1.5.1 SETTING THE PRELOAD

The preload can be measured and set using different methods:

- using pressure screws with a setting torque according to the table on page 33
- by means of FRV carriage displacement resistance (see below)
- by measuring the deformation of the connecting structure.

$$F_{RV} = \frac{C_{0w}}{40'000}$$

F_{RV}	N	Carriage displacement resistance
C_{0w}	N	Effective static load rating

Requirements:

- Preload 2,5% C_0
- Lubricated guidance system without operating load
- Movement at approx. 0,05 m/s

1.5.1.1 PRELOAD SCREWS

In the case of small loads ($S_0 > 5$) the guidance system can be preloaded by means of preload screws. A smaller effective span can be obtained by inserting the preload screws (stud screws according to ISO 4026, DIN 913) between the attachment screws and at the end of the guideway (table 18, figure 19).

1.5.1.2 GUIDEWAYS WITH ADJUSTING GIB

The use of ML guideways with an adjusting gib is recommended where a high degree of rigidity is required or with larger loads ($S_0 < 5$). This ensures that the preload is distributed evenly over the entire guideway length.

TABLE 18. PRELOAD SCREWS / SETTING TORQUE

Guideways	Flat cage assembly	Preload screw		Setting torque
		Dimension	Distance / mm	$M_E^{1)}$ / Nm
M / V 3015	E-HW10	M4	40	0.34
M / V 4020	E-HW15	M6	80	1.2
M / V 5025	E-HW16	M6	80	1.8
M / V 4525	E-HRW50	M6	80	1
M / V 6035	E-HW20	M8	100	2.9
M / V 6535	E-HRW70	M8	100	3.5
M / V 7040	E-HW25	M10	100	5.7
M / V 8050	E-HW30	M12	100	7.7

1) Torque for a preload of 2,5% C_0

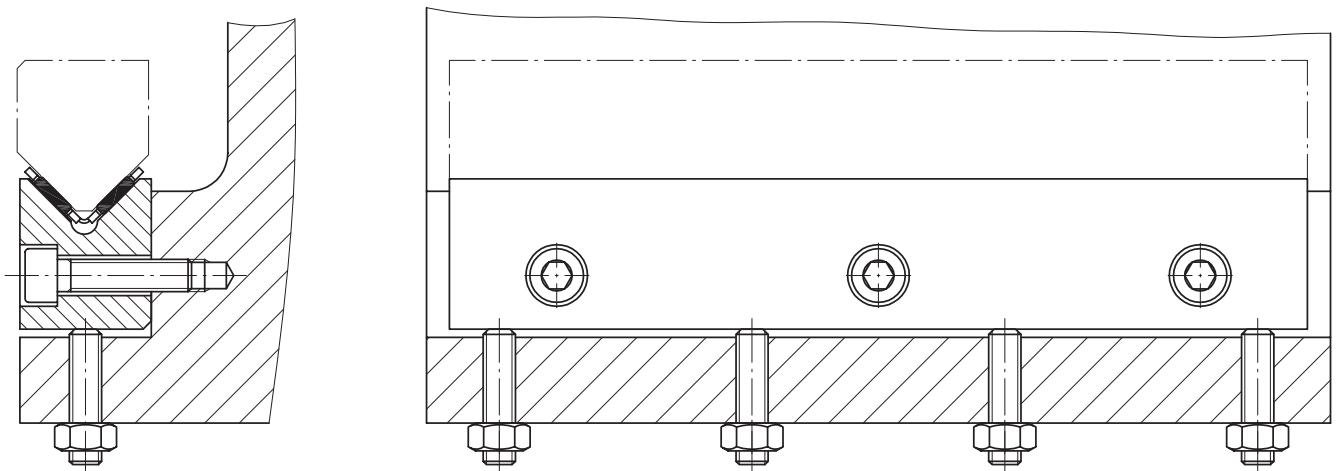

Figure 19. Position of the pressure screws

1.6 LUBRICATION

Machine performance is influenced considerably by the installed flat cage guidance systems. Lubrication plays an important role in this context.

The lubricant minimises friction and wear in the rolling contact and at the bearing points between the cage and the rolling elements. Lubricants also protect against corrosion and offer a support to the seal.

1.6.1 LUBRICANTS

Grease or oil can be used as lubricants. The choice of lubrication procedure is made on the basis of technical and economic considerations:

Advantages of lubrication with grease:

- long relubrication intervals
- reduced structural expenditure when relubrication is not required
- thickener in the grease creates emergency operation features
- support to the seal

Advantages of lubrication with oil:

- excellent lubrication application
- dirt is flushed out
- heat is dissipated

Flat cage guidance systems only require minimal lubrication. They are supplied with a preservative. The preservative is compatible with grease and oils.

Flat cage guidance systems are generally operated in areas of mixed friction. For this reason, doped lubricants with high-pressure additives should be used (code letter P according to DIN 51502).

△ Cooling lubricants must not be used as they thin out the lubricants and can cause corrosion. Lubricants with solid additives must not be used.

1.6.2 LUBRICATING WITH GREASE

General recommendation:

Lithium-soap, EP-doped grease with mineral oil base.
Specification according to DIN 51825: KP2N-20
Base oil viscosity: ISO-VG 150 to ISP-VG220.

△ $S_0 < 8$ essential with large loads
EP-doped greases with base oil viscosity of ISO-VG 220 should be used.

1.6.2.1 PRIMARY OPERATION AND GREASE QUANTITY

The guidance system must be protected against soiling before and during assembly.

Without relubrication equipment:

For the first lubrication application, spread the grease quantity according to the table over both sides in the cage pockets and thinly lubricate the guideway raceways.

With relubrication equipment:

First fill the feed line with grease and thinly lubricate the raceways. Then assemble the guidance system and feed in the grease according to the table. Move the guide system several times during this procedure over the entire stroke to ensure that the grease is evenly distributed.

TABLE 20. GREASE QUANTITIES FOR PRIMARY LUBRICATION (GUIDELINES)

Flat cage/Series	Grease quantity for primary lubrication g/100 mm cage length ¹⁾
E-HW 10	0.6
E-HW 15 ²⁾ / E-FFW 2025 / E-FF 2025 ZW	0.6
E-HW 20 ²⁾ / E-FFW 2535 / E-FF 2535ZW	1
E-HW 25 ²⁾ / E-FFW 3045 / E-FF 3045 ZW	1.3
E-HW 30 ²⁾ / E-FFW 3555 / E-FF 3555 ZW	2.1
E-HRW 50	1.5
E-HRW 70	3.5
E-HRW 100	6.6
E-H 10 ²⁾ / E-FF 2010	0.3
E-H 15 ²⁾ / E-FF 2515	0.5
E-H 20 ²⁾ / E-FF 3020	0.7
E-H 25 ²⁾ / E-FF 3525	1.1

1) In case of high speeds only about 25% of the quantity

2) With flat cage assemblies with damping about 80% of the quantity

1.6.2.2 RELUBRICATION

Relubrication should be carried out at least once a year with approximately 50% of the grease quantity used for the primary lubrication. More frequent relubrication with partial quantities is recommended. The optimum time and quantities can only be determined under operating conditions and with an adequate observation period.

1.6.3 LUBRICATING WITH OIL

General recommendation:

CLP lubricating oils according to DIN 51517 and
HLP according to DIN 51524

Operating temperatures from 0 °C to +70 °C:
Viscosity between ISO-VG 32 and ISO-VG 68

Low temperature range:
Viscosity ISO-VG 10 to ISO-VG 22

CGLP raceway oils can be used up to ISO-VG 220

Oil is fed in by oil impulse or drop feed. Pneumatic oil lubrication is recommended for working conditions with a significant risk of soiling. The slight excess pressure occurring in the guidance system enhances the effectiveness of the existing seals.

It is important to observe the layout (figure 21) when feeding in the lubricating oil so that the lubricant can reach all the rolling element rows.

If the oil manufacturer has not provided any details or experiences, the behaviour of the lubricating oil must be verified under operating conditions in comparison with the materials used in the guidance system.

Mineral oils can generally be mixed together.

However, synthetic oils must be verified in relation to miscibility and compatibility.

In case of doubt, contact the lubricant supplier.

Primary operation

Oil the guidance system and protect it against soiling during assembly.

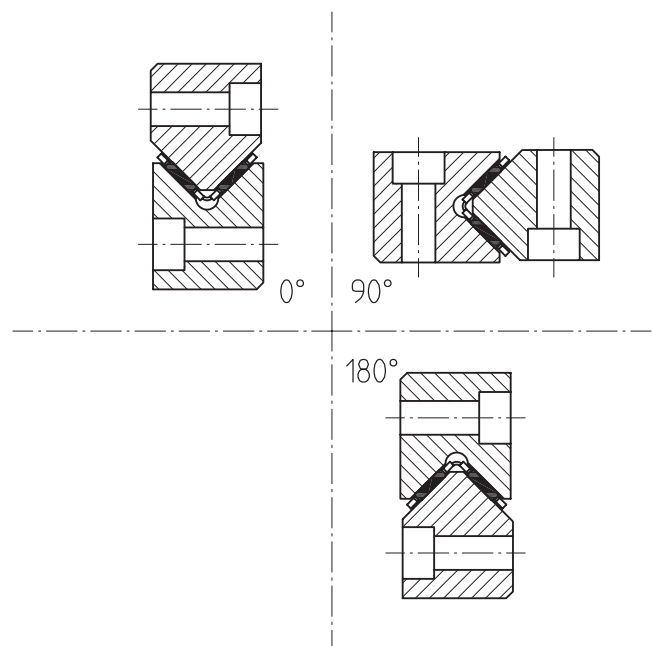

Figure 21. Layouts

1.7 FRICTION

As is the case of all roller bearings, flat cage guidance systems have virtually low friction during the start-up process and in motion. This means that no “stick-slip effect” is produced compared with sliding friction.

Friction (displacement resistance FR) is made up of the following components with different dependencies:

$$F_R = F_{R1} + F_{R0} + F_{RA}$$

Friction component		Dependency
Rolling friction	F_{R1}	Load/lubrication condition
Lubricant friction	F_{R0}	Cage dimensions Stroke speed Lubricant
Wiper friction	F_{RA}	Configuration, preload

Primary lubrication or relubrication produce temporarily raised lubrication friction.

Wiper friction F_{RA}

The wiper friction arises from the length of the wiper lip and the lip preload. This can be influenced considerably by the wiper assembly.

Reference value per wiper:

Profile shape M/V $F_{RA} = 0.20 \cdot B$

Profile shape J/S $F_{RA} = 0.15 \cdot B$

F_{RA}	N	Friction per wiper
B	mm	Guideway width

Load-dependent rolling friction F_{R1}

$$F_{R1} = \mu \cdot F$$

F_{R1}	N	Load-dependent friction component
F	N	Flat cage load
μ	-	Friction coefficient

With lubrication, the friction coefficient amounts to
 0.00035 for flat cage assemblies
 0.00050 for angled flat cage assemblies

Lubricant friction F_{R0}

$$F_{R0} = f_0 \cdot (v \cdot v)^{2/3} \cdot B1 \cdot L_k^{1/3} \cdot 10^{-6}$$

F_{R0}	N	Lubricant friction component in displacement friction
f_0	-	Type factor $f_0 = 85$ for flat cage assemblies $f_0 = 120$ for angled flat cage assemblies
v	mm²s⁻¹	Lubricant viscosity at operating temperature Viscosity of base oil with grease lubrication
v	m/min	Speed
B1	mm	Cage width
L_k	mm	Bearing cage length

1.8 PROTECTION AGAINST SOILING

In order to ensure that flat cage guidance systems operate safely it is extremely important to protect them against soiling.

In many cases, wipers will suffice to keep the raceways clean. They must be positioned on the raceways throughout the entire movement.

Complete solutions for M and V guideways with standard wipers and integrated longitudinal seals (suffix ..ZZ, ..PP) or seals in the connecting structure may be used for more demanding cases.

1.9 OPERATING LIMITS

1.9.1 Operating temperatures

Linear guidance systems with metallic flat cages are suitable for continuous temperatures of up to +150 °C.

Suitable lubricants must be used in this case. The guideways must be heat-stabilised at higher operating temperatures (further information can be obtained from EGIS).

Linear guidance systems with flat cages made from plastic are suitable for temperatures of up to +120°C.

An operating temperature of +100 °C must not be exceeded when using wipers.

1.9.2 Accelerations

If high accelerations are recorded in a linear guidance system, EGIS light metal flat cages are particularly recommended due to their reduced weight. They can be used for accelerations up to 250 m/s².

1.9.3 Speeds

Under normal conditions, speeds of up to 120 m/min can be achieved. These values depend on the size of the guide, on the lubrication, on the preload, on the load, type of mounting, and the selected rail.

1.10 INSTALLATION GUIDELINES

1.10.1 PRECISION OF THE CONNECTING STRUCTURE

The precision of the locating surfaces has a decisive influence on the accuracy and smooth running of a linear guidance system.

Perpendicularity and parallelism

The right angle between the locating surfaces must be maintained precisely (permissible error $\pm 0,3$ mrad)

\perp 0.003/10

Parallelism errors on the locating surfaces must not be significantly greater than the corresponding tolerances of the guideways.

Height variation

In order to ensure that the load is distributed as equally as possible over the length of the rolling element, the height variation Δh should not be exceeded (figures 22 and 23).

Permissible height variation for needle roller flat cage assemblies

$$\Delta h < 0,1 \cdot b$$

Permissible height variation for cylinder roller flat cage assemblies

$$\Delta h < 0,3 \cdot b$$

Δh	μm	Permissible height variation
b	mm	Distance between guidance system centres

Surface

No particular demands are placed on the surface roughness of the locating surfaces from an operational point of view. In order to maintain a high level of form precision and a suitable measurement basis, it is nevertheless recommended that the surfaces should be precision machined and the holes carefully deburred.

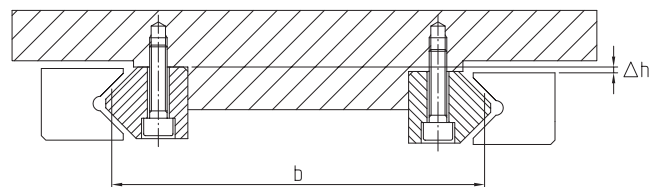

Figure 22. Height variation with a closed layout

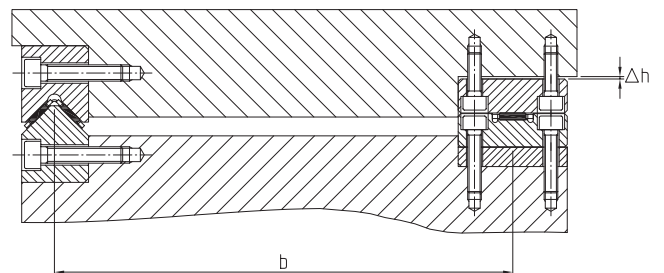

Figure 23. Equalisation of the height variation with an open layout with an insert plate

1.10.2 ASSEMBLY INSTRUCTIONS

1.10.2.1 PRIOR TO INSTALLATION

Guideways are preserved and delivered packed in anticorrosion paper. Parts are matched by dimensions, packed in sets and numbered accordingly.

Numbering:



Unpack guideways shortly before assembly and remove the corrosion protection where applicable. Light oiling protects the guideways against corrosion during assembly. Position parts with identical set number.

Particular attention should be paid to the following points:

- Guideways with the same set number should be inserted in the same guidance system during assembly.
- Attention should be paid to the joint number at the joints.
- The M and V guideways may have different set numbers in the closed layout (figure 24).

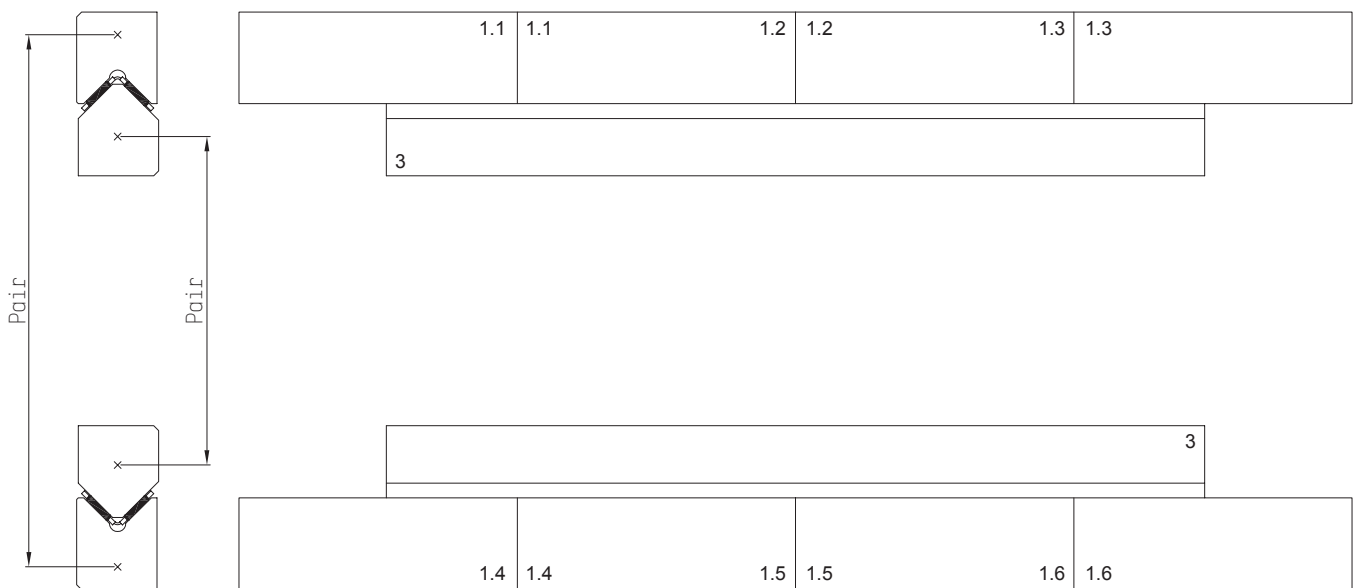

Figure 24. Numbering of single and multi-part guideways

1.10.2.2 CLOSED LAYOUT

△ Guideways which are packed in pairs must always be installed in the same guidance system.

The guideway locating faces are unlabelled and comprise significant chamfer.

Assemble the guideway pair which does not require adjustment (1) (figure 25). Clamp the guideways against the rear locating face and check for parallelism before tightening the fixing screws (figure 26).

Assemble the stationary opposing guideway (2)

Attach the adjusting guideway (3), only tightening screws slightly so that the guideway can still move.

Insert guidance system lengthways, insert cage assemblies between the guideways and position so that they do not lie against the end pieces in the final positions.

Preload adjusting guideway (3) with pressure screws (4) (figure 27) (with gib for ML guideways) (figures 29 to 31).

Initially preload around twice the required value in order to anticipate settling. Release and then set the preload to the required value. Tighten fixing screws. Screw on wipers or end pieces.

When preloading with pressure screws, adjust the latter in two steps to the required tightening torque and tighten with a counter nut or screw locking device.

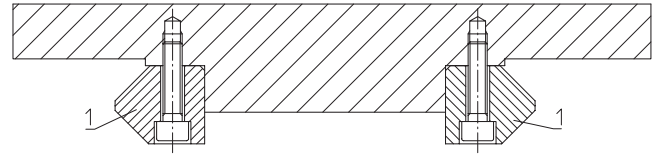

Figure 25. Assembly.

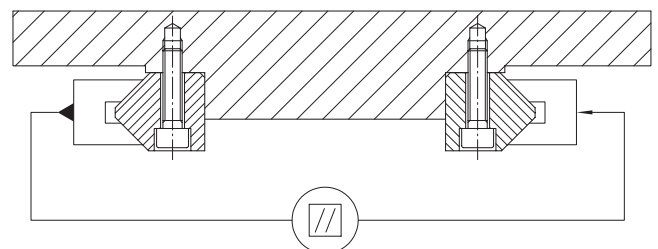

Figure 26. Parallelism verification

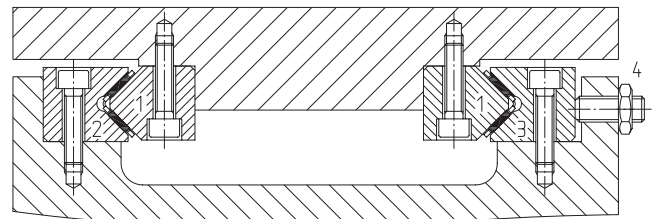

Figure 27. Preload.

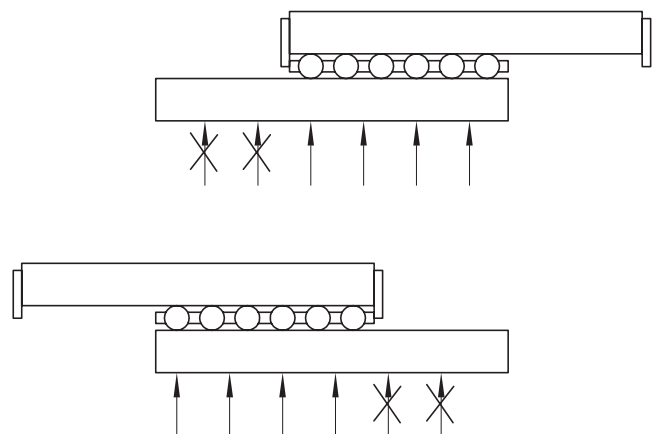

Figure 28. Preload adjustment.

△ Only tighten pressure screws which are supported by the flat cage assembly (see figure 28).

If the preload force is adjusted over ML- guideways with an adjusting gib, the following procedure should be followed: push the adjusting gib under the ML guideway and adjust the guidance system free from clearance (figure 29). Shorten the unhardened gib on the adjustment side of the guideway so that it is approximately 3 mm short of the front side of the guideway (figure 29). Shorten the opposite side of the gib flush with the end of the guideway.

Preload the gib by inserting a soft bolt (figure 30). A 1 mm displacement of the gib produces a height adjustment of 15 μm .

After setting, attach the adjusting gib to the front side of the guideway with the hexagonal socket screw (figure 31).

See chapter entitled "Setting the preload" to verify the preload

1.10.2.3 OPEN LAYOUT

After the precision of the locating faces has been checked, particularly the height variation (see chapter on the precision of the connecting parts), the guideways can be assembled in the required sequence.

Guideways which are labelled in sets (4SX matching) must be assembled accordingly.

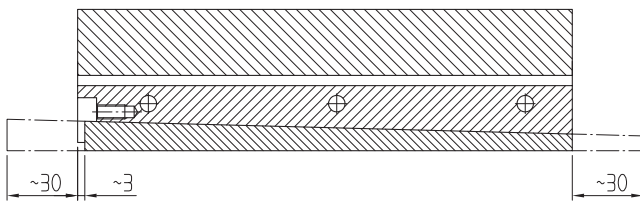

Figure 29. Inserting and shortening the adjusting gib

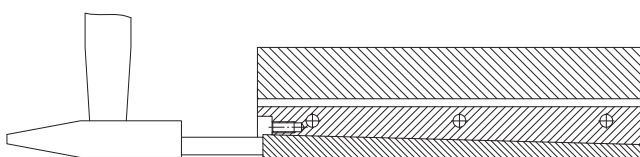

Figure 30. Setting the preload

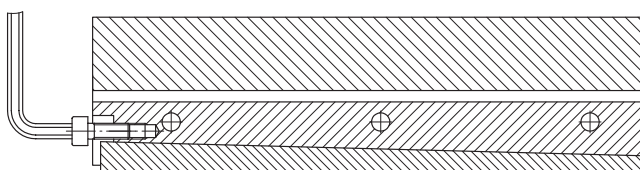
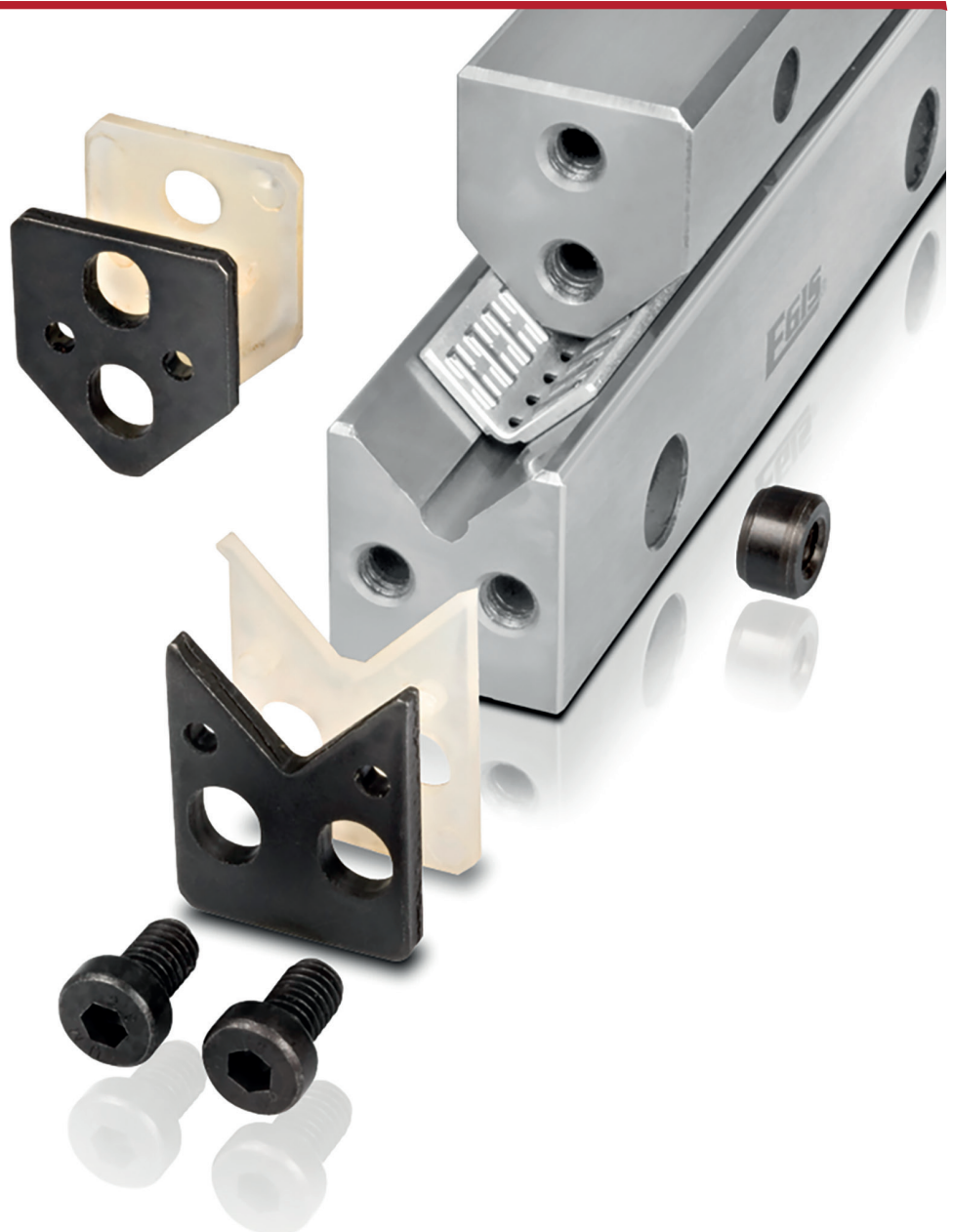

Figure 31. Attaching the adjusting gib

PRODUCT PROGRAMME

2

M AND V GUIDEWAYS WITH NEEDLE OR CYLINDRICAL ROLLER FLAT CAGE ASSEMBLY



A MATERIAL

Hardened tool steel 1.2842 HRc 58 – 62.

B QUALITY

Raceways and locating faces are precision ground.

The guideways are available in 3 qualities (parallelism tolerance of the raceways on the reference sides of the guideway in relation to a defined length).

- Q10: normal quality for general machine construction
- Q6: precise quality for machine tool construction
- Q2: particularly precise quality for exceptionally demanding structures

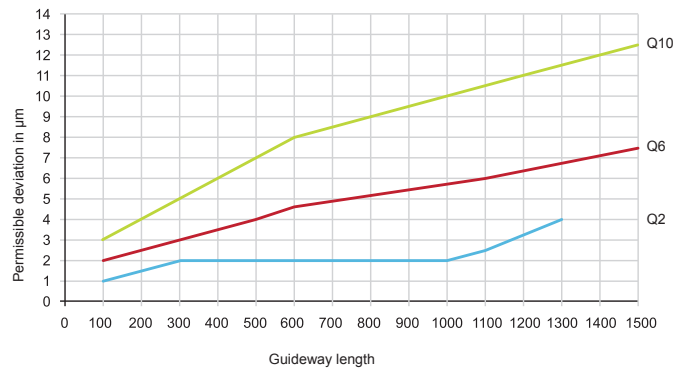

SPECIAL EXECUTIONS
SEE CHAPTER 10 ALTERNATIVE VERSIONS

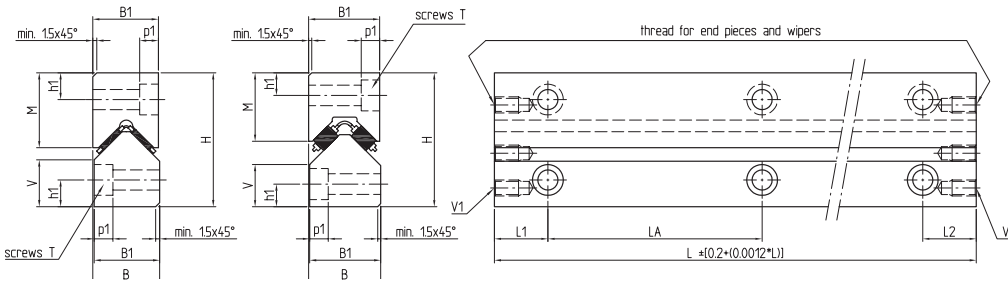

DIMENSIONS IN (MM)

Type	External dimensions					Fixing holes											Threads
	H 0/-0.2	B 0/-0.1	B1 0/-0.2	M	V	Screws T ****	d	f	h	h1	p1 min.	t min.	LA***	L1** min.	L2** min.	V1	
M3015	30	15	15	15.75	-	M4	8,5	5,25	M4	5,5	4,6	15	40*	15	15	M3	
V3015				-	10,5												
M4020	40	20	20	22.5	-	M6	11,5	7,5	M6	7,5	6,9	20	80*	15	15	M5	
V4020				-	13,5												
M4525	45	25	25	22.75	-	M6	11,5	7,5	M6	7,5	6,9	15	100	20	20	M6	
V4525				-	14												
M5025	50	25	25	28	-	M6	11,5	7,5	M6	10	6,9	15	80*	20	20	M6	
V5025				-	17												
M6035	60	35	35	35	-	M8	15	10	M8	11	9,1	20	100	20	20	M6	
V6035				-	20												
M6535	65	35	35	33.25	-	M8	15	10	M8	11	9,1	20	100	20	20	M6	
V6535				-	20												
M7040	70	40	40	40	-	M10	18,5	12,5	M10	13	11,1	25	100	20	20	M6	
V7040				-	24												
M8050	80	50	50	45	-	M12	20	14	M12	14	13,1	30	100	20	20	M6	
V8050				-	26												
M8550	85	50	50	42.25	-	M12	20	14	M12	14	13,1	30	100	20	20	M6	
V8550				-	26												

Type	External dimensions					Fixing holes											Threads
	H 0/-0.2	B 0/-0.1	B1 0/-0.2	M	V	e	d	f	Screws T ****	h1	p1 min.	t min.	LA***	L1** min.	L2** min.	V1	
M3115	31	15	15	16	-	M6	9,5	5,2	M5	6	5,2	15	50*	15	15	M3	
V3115				-	11												
M4422	44	22	22	24	-	M8	11,5	7,5	M6	9	6,9	22	100	20	20	M4	
V4422				-	15												
M5225	52	25	25	28	-	M10	15	10	M8	10	9,1	15	100	20	20	M6	
V5225				-	29												
M6230	62	30	30	34	-	M12	18,5	12,5	M10	12	11,1	19,8	100	20	20	M6	
V6230				-	35												
M7435	74	35	35	42.5	-	M14	20	14	M12	14	13,1	25	100	20	20	M6	
V7435				-	40												
M7845	78	45	45	45	-	M14	20	14	M12	14	13,1	25	100	20	20	M6	
V7845				-	45												

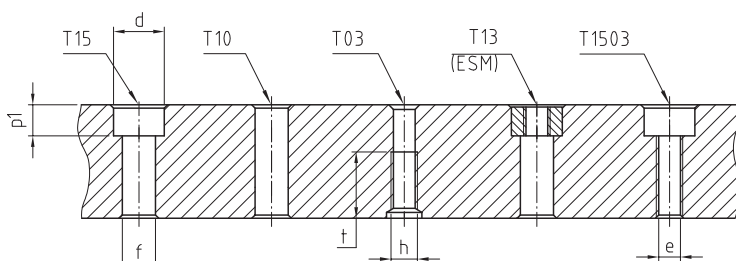

- T15: Sinkhole for screws ISO 4762
- T10: Clearance hole
- T03: Threaded hole, thread length "t"
- T13: Sinkhole as T15, but with insert nuts ESM
- T1503: Sunk holes as T15, but with threaded passage diameter (e)

STANDARD LENGTHS (MM)

CAGE ALLOCATION

	100	150	200	300	400	500	600	700	800	900	1000	L/max	Rolling elements	Plastic	Aluminium	Steel	Brass	Brass (with damping)
	●	●	●	●	●	●	●					600	Needle rollers		E-HW10 AL	E-HW10 F	E-HW10 MS	
	●	●	●	●	●	●	●	●	●	●	●	1'000	Needle rollers	E-FFW2025	E-HW15 AL	E-HW15 F	E-HW15 MS	E-HGW15
	●		●	●	●	●	●	●	●	●	●	1'000	Cylindrical rollers		E-HRW50			
	●		●	●	●	●	●	●	●	●	●	1'300	Needle rollers	E-FFW2025	E-HW15 AL E-HW16 AL	E-HW15 F	E-HW15 MS E-HW16 MS	E-HGW15
			●	●	●	●	●	●	●	●	●	1'300	Needle rollers	E-FFW2535	E-HW20 AL	E-HW20 F	E-HW20 MS	E-HGW20
			●	●	●	●	●	●	●	●	●	1'300	Cylindrical rollers		E-HRW70			
			●	●	●	●	●	●	●	●	●	1'300	Needle rollers	E-FFW3045	E-HW25 AL	E-HW25 F	E-HW25 MS	E-HGW25
			●	●	●	●	●	●	●	●	●	1'300	Needle rollers	E-FFW3555	E-HW30 AL	E-HW30 F	E-HW30 MS	E-HGW30
			●	●	●	●	●	●	●	●	●	1'300	Cylindrical rollers		E-HRW100			

	100	150	200	300	400	500	600	700	800	900	1000	L/max	Rolling elements	Plastic	Aluminium	Steel	Brass	Brass (with damping)
	●	●	●	●	●	●	●					600	Needle rollers		E-HW10 AL	E-HW10 F	E-HW10 MS	
	●		●	●	●	●	●	●	●	●	●	1'000	Needle rollers	E-FFW2025	E-HW15 AL	E-HW15 F	E-HW15 MS	E-HGW15
			●	●	●	●	●	●	●	●	●	1'000	Needle rollers	E-FFW2025	E-HW15 AL E-HW16 AL	E-HW15 F	E-HW15 MS E-HW16 MS	E-HGW15
			●	●	●	●	●	●	●	●	●	1'300	Needle rollers	E-FFW2535	E-HW20 AL	E-HW20 F	E-HW20 MS	E-HGW20
												1'300	Needle rollers	E-FFW3045	E-HW25 AL	E-HW25 F	E-HW25 MS	E-HGW25
												1'300	Needle rollers	E-FFW3555	E-HW30 AL	E-HW30 F	E-HW30 MS	E-HGW30

* MV3015: length (L) 100mm, hole distances (LA) = 35mm
 MV4422: length (L) 100mm, hole distances (LA) = 50mm
 MV5025: length (L) 100mm, hole distances (LA) = 50mm

* M/V4020: length (L) 100mm, hole distances (LA) = 50mm
 M/V4525: length (L) 100mm, hole distances (LA) = 50mm

** L1 and L2 are the same size at both ends of the guideways and dependent on the guideway length without any specific requests being made

*** The tolerance of the hole distances (LA) is in proportion to the length tolerance

**** 5 holes types in the guideways for screw size T (according to the drawing below)

***** Special screw with reduced diameter. Please ask us.

Further information can be found in the chapter Linear Cages.

● = Standard lengths
 Special lengths available on request

3

ML GUIDEWAYS WITH ADJUSTING GIB AND V GUIDEWAYS WITH NEEDLE ROLLER FLAT CAGE ASSEMBLY



A MATERIAL

Hardened tool steel 1.2842 HRc 58 – 62
(non-hardened adjusting gib).

B QUALITY

Raceways and locating faces are precision ground.

The guideways are available in 2 qualities for the ML guideways and 3 qualities for the V guideways (parallelism tolerance of the raceways on the reference sides of the guideways in relation to a defined length).

- Q10: normal quality for general machine construction (ML and V)
- Q6: precise quality for machine tool construction (ML and V)
- Q2: particularly precise quality for exceptionally demanding structures (V)

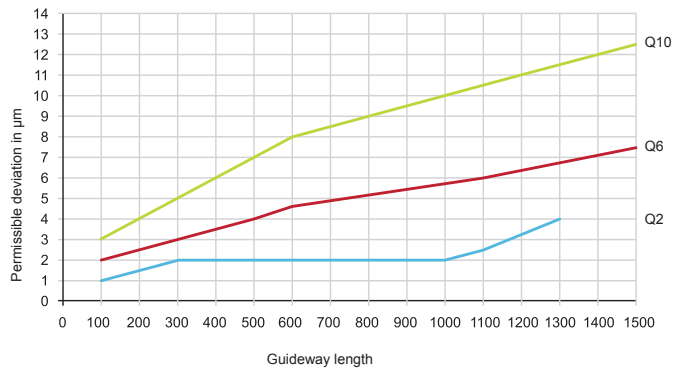

SPECIAL EXECUTIONS
SEE CHAPTER 10 ALTERNATIVE VERSIONS

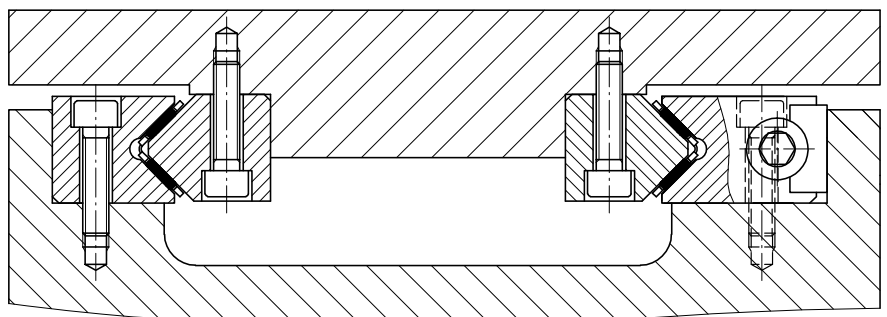

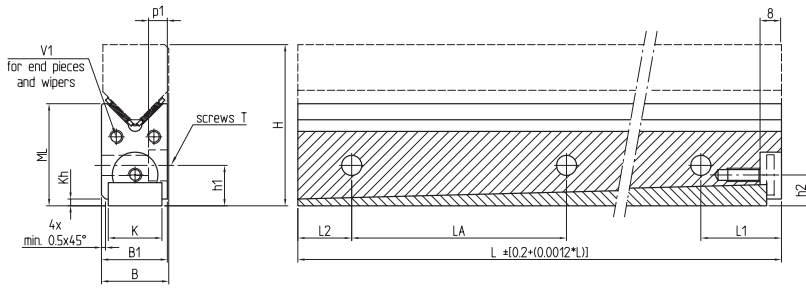

DIMENSIONS IN (MM)

Type	External dimensions						Fixing holes										Threads
	H 0/-0.2	B 0/-0.1	B1 0/-0.2	ML*	K	Kh*	Screws T ****	d	f	h	h1	p1 min.	t min.	LA***	L1*** min.	L2*** min.	
ML5020	50	20	20	32.5	15	5.5	M6	11.5	7.5	M6	17.5	4.6	20	8	30	15	M4
ML5520	55	20	20	37.5	15	6	M6	11.5	7.5	M6	22.5	5.2	20	80	30	15	M4
ML5525	55	25	25	32.5	20	2.5	M6	11.5	7.5	M6	15	6.9	15	80	30	20	M5
ML6025	60	25	25	37.5	20	3.5	M6	11.5	7.5	M6	20	6.9	15	80	30	20	M5
ML6525	65	25	25	42.5	20	5	M6	11.5	7.5	M6	25	6.9	15	80	30	20	M5
ML7025	70	25	25	47.5	20	6.5	M6	11.5	7.5	M6	30	6.9	15	80	30	20	M5
ML7035	70	35	35	45	25	3	M8	15	10	M8	21	6.9	20	100	32	20	M6
ML8035	80	35	35	55	25	5	M8	15	10	M8	31	9.1	20	100	32	20	M6
ML8040	80	40	40	50	30	3	M10	18.5	12.5	M10	23	9.1	25	100	32	20	M6
ML9040	90	40	40	60	30	5	M10	18.5	12.5	M10	33	9.1	25	100	32	20	M6
ML9050	90	50	50	55	40	3	M12	20	14	M12	24	11.1	30	100	32	20	M6
ML10050	100	50	50	65	40	5	M12	20	14	M12	34	11.1	30	100	32	20	M6

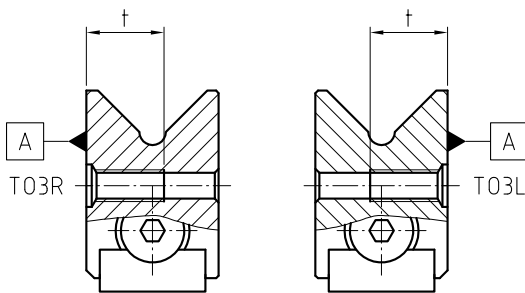

T15: Sinkhole for screws ISO 4762
 Depending on left or right guideway
 T03: Threaded hole, thread length "t"
 Depending on left or right guideway
 T13: Sinkhole as T15, but with insert nuts ESM
 Depending on left or right guideway
 [A]: Reference side

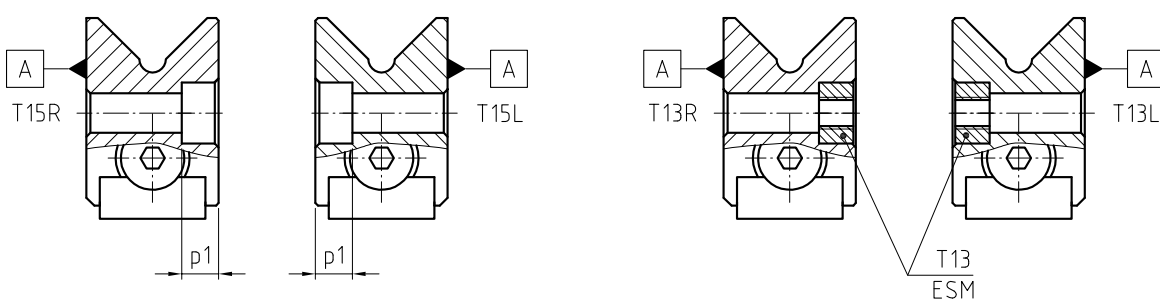

STANDARD LENGTHS (MM)

CAGE ALLOCATION

	100	200	250	300	400	500	600	700	750	800	900	1000	Rolling elements	Plastic	Aluminium	Steel	Brass	Brass (with damping)
	●	●		●									Needle rollers	E-FFW2025	E-HW15 AL	E-HW15 F	E-HW15 MS	E-HGW15
				●	●	●							Needle rollers	E-FFW2025	E-HW15 AL	E-HW15 F	E-HW15 MS	E-HGW15
	●	●	●										Needle rollers	E-FFW2025	E-HW15 AL E-HW16 AL	E-HW15 F	E-HW15 MS E-HW16 MS	E-HGW15
			●	●	●								Needle rollers	E-FFW2025	E-HW15 AL E-HW16 AL	E-HW15 F	E-HW15 MS E-HW16 MS	E-HGW15
						●	●	●					Needle rollers	E-FFW2025	E-HW15 AL E-HW16 AL	E-HW15 F	E-HW15 MS E-HW16 MS	E-HGW15
	●	●		●	●	●							Needle rollers	E-FFW2535	E-HW20 AL	E-HW20 F	E-HW20 MS	E-HGW20
						●	●		●	●	●		Needle rollers	E-FFW2535	E-HW20 AL	E-HW20 F	E-HW20 MS	E-HGW20
	●	●		●	●	●							Needle rollers	E-FFW3045	E-HW25 AL	E-HW25 F	E-HW25 MS	E-HGW25
						●	●		●	●	●		Needle rollers	E-FFW3045	E-HW25 AL	E-HW25 F	E-HW25 MS	E-HGW25
	●	●		●	●	●							Needle rollers	E-FFW3555	E-HW30 AL	E-HW30 F	E-HW30 MS	E-HGW30
						●	●		●	●	●		Needle rollers	E-FFW3555	E-HW30 AL	E-HW30 F	E-HW30 MS	E-HGW30

Further information can be found in the chapter Linear Cages.

● = Standard lengths
 Special lengths available on request

* These dimensions are dependent on the gib position, adjustment range ± 0.5
 ** ML5020 + ML5525 + ML7035 + ML8040 + ML9050: length (L) 100mm, hole distance (LA) = 50mm
 The tolerance of the hole distances (LA) is in proportion to the length tolerance
 *** L1 and L2 are the same size at both ends of the guideways and dependent on the guideway length without any specific requests being made
 **** 3 hole types in the guideways for screw size T (according to the drawing below)

4

GUIDEWAYS WITH INTEGRATED TOOTHED RACK MVZ (M/V/ML) FOR POSITIVE CONTROL OF THE NEEDLE ROLLER FLAT CAGE ASSEMBLY



A MATERIAL

Hardened tool steel 1.2842 HRc 58 – 62.

B QUALITY

Raceways and locating faces are precision ground.

The guideways are available in 3 qualities (parallelism tolerance of the raceways on the reference sides of the guideway in relation to a defined length).

- Q10: normal quality for general machine construction
- Q6: precise quality for machine tool construction
- Q2: particularly precise quality for exceptionally demanding structures

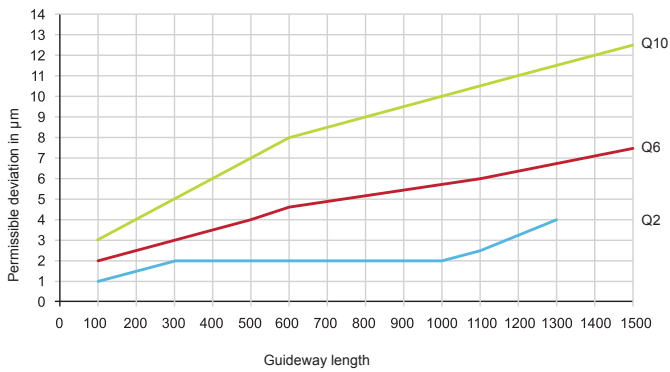

SPECIAL EXECUTIONS
SEE CHAPTER 10 ALTERNATIVE VERSIONS

C MATCHING BY SETS

MVZ – guideways with integrated toothed rack are supplied in sets and consist of:

- M and/or ML guideways with integrated toothed rack.
- V guideways with integrated toothed rack.
- Flat cage assemblies: E-HW F or E-HW with integrated toothed wheel for positive control of the cage assemblies.
- The assembly dimensions have the same mounting dimensions as the M/ML and V guideways with flat cage assemblies.

IMPORTANT ASSEMBLY INFORMATION

- Set numbering must be respected.
- When the guideways are being positioned, it is important to take into account the “X-X” labelling which guarantees the correct positioning of the guideways and cage assemblies in the central stroke position.

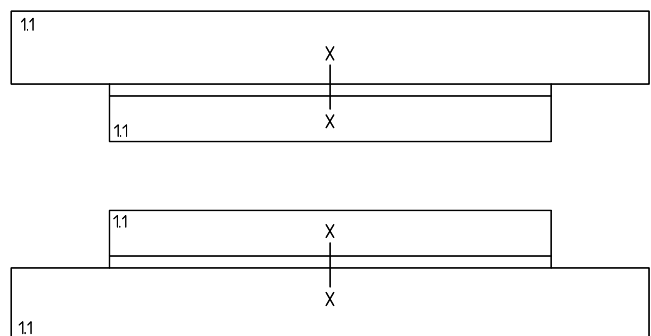

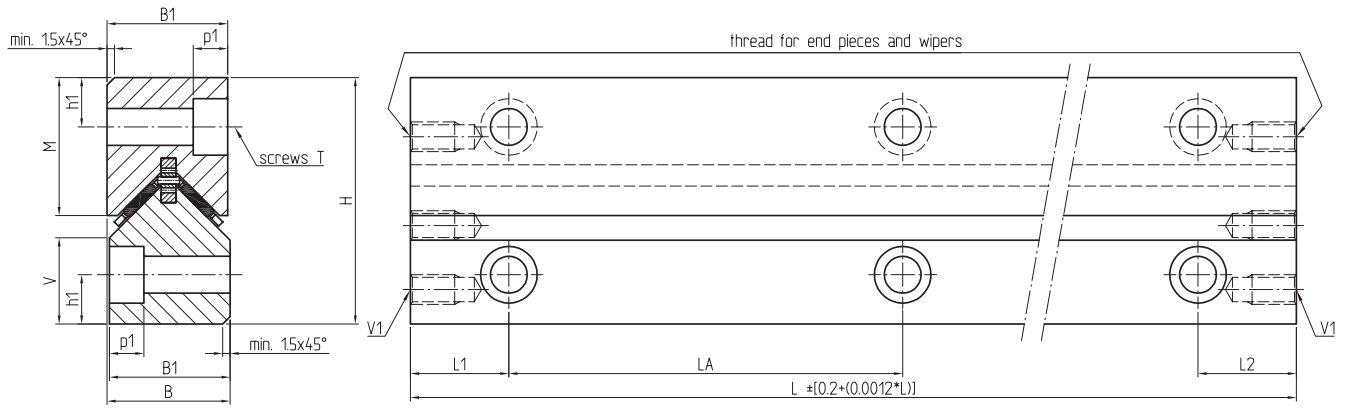

DIMENSIONS IN (MM)

Type	External dimensions					Fixing holes										Threads	
	H 0/-0.2	B 0/-0.1	B1 0/-0.2	M	V	Screws T ****	d	f	h	h1	p1 min.	t min.	LA***	L1** min.	L2** min.	V1	
M3015	30	15	15	15.75	-	M4	8.5	5.25	M4	5.5	4.6	15	40*	15	15	M3	
V3015				-	10.5												
M4020	40	20	20	22.5	-	M6	11.5	7.5	M6	7.5	6.9	20	80*	15	15	M5	
V4020				-	13.5												
M5025	50	25	25	28	-	M6	11.5	7.5	M6	10	6.9	15	80*	20	20	M6	
V5025				-	17												
M6035	60	35	35	35	-	M8	15	10	M8	11	9.1	20	100	20	20	M6	
V6035				-	20												
M7040	70	40	40	40	-	M10	18.5	12.5	M10	13	11.1	25	100	20	20	M6	
V7040				-	24												
M8050	80	50	50	45	-	M12	20	14	M12	14	13.1	30	100	20	20	M6	
V8050				-	26												

Type	External dimensions					Fixing holes										Threads	
	H 0/-0.2	B 0/-0.1	B1 0/-0.2	M	V	e	d	f	Screws T *****	h1	p1 min.	t min.	LA***	L1** min.	L2** min.	V1	
M3115	31	15	15	16	-	M6	9.5	5.2	M5	6	5.2	15	50*	15	15	M3	
V3115				-	11												
M4422	44	22	22	24	-	M8	11.5	7.5	M6	9	6.9	22	100	20	20	M4	
V4422				-	15												
M5225	52	25	25	28	-	M10	13.5	8.5	M8	10	8.2	15	100	20	20	M6	
V5225				-	29												
M6230	62	30	30	34	-	M12	16.5	10.5	M10	12	10.2	19.8	100	20	20	M6	
V6230				-	35												
M7435	74	35	35	42.5	-	M14	18.5	12.5	M12	14	12.2	25	100	20	20	M6	
V7435				-	40												
M7845	78	45	45	45	-	M14	18.5	12.5	M12	14	12.2	25	100	20	20	M6	
V7845				-	45												

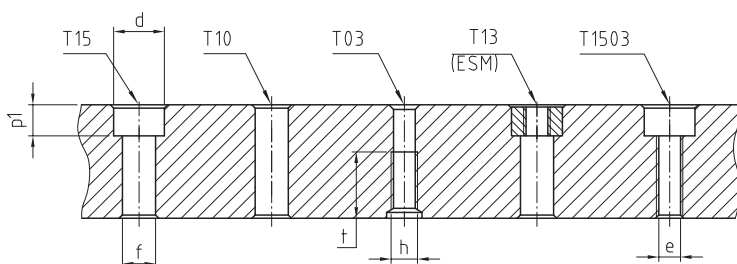

- T15: Sinkhole for screws ISO 4762
- T10: Clearance hole
- T03: Threaded hole, thread length "t"
- T13: Sinkhole as T15, but with insert nuts ESM

STANDARD LENGTHS (MM)

CAGE ALLOCATION

100	150	200	300	400	500	600	700	800	900	1000	L/max	Rolling elements	Aluminium	Steel	Brass
●	●	●	●	●	●	●					600	Needle rollers	E-HW10 AL-MVZ	E-HW10 F-MVZ	E-HW10 MS-MVZ
●	●	●	●	●	●	●	●	●	●	●	1'000	Needle rollers	E-HW15 AL-MVZ	E-HW15 F	E-HW15 MS
●		●	●	●	●	●	●	●	●	●	1'300	Needle rollers	E-HW15 AL-MVZ	E-HW15 F	E-HW15 MS
		●	●	●	●	●	●	●	●	●	1'300	Needle rollers	E-HW20 AL-MVZ	E-HW20 F-MVZ	E-HW20 MS-MVZ
		●	●	●	●	●	●	●	●	●	1'300	Needle rollers	E-HW25 AL-MVZ	E-HW25 F-MVZ	E-HW25 MS-MVZ
			●	●	●	●	●	●	●	●	1'300	Needle rollers	E-HW30 AL-MVZ	E-HW30 F-MVZ	E-HW30 MS-MVZ

100	150	200	300	400	500	600	700	800	900	1000	L/max	Rolling elements	Aluminium	Steel	Brass
●	●	●	●	●	●	●					600	Needle rollers	E-HW10 AL-MVZ	E-HW10 F-MVZ	E-HW10 MS-MVZ
●		●	●	●	●	●	●	●	●	●	1'000	Needle rollers	E-HW15 AL-MVZ	E-HW15 F	E-HW15 MS
		●	●	●	●	●	●	●	●	●	1'300	Needle rollers	E-HW15 AL-MVZ	E-HW15 F	E-HW15 MS
		●	●	●	●	●	●	●	●	●	1'300	Needle rollers	E-HW20 AL-MVZ	E-HW20 F-MVZ	E-HW20 MS-MVZ
											1'300	Needle rollers	E-HW25 AL-MVZ	E-HW25 F-MVZ	E-HW25 MS-MVZ
											1'300	Needle rollers	E-HW30 AL-MVZ	E-HW30 F-MVZ	E-HW30 MS-MVZ

Further information can be found in the chapter Linear Cages.

● = Standard lengths
 Special lengths available on request

* M/V3015: length (L) 100mm, hole distances (LA) = 35mm
 M/V4020: length (L) 100mm, hole distances (LA) = 50mm
 M/V5025: length (L) 100mm, hole distances (LA) = 50mm
 ** L1 and L2 are the same size at both ends of the guideways and dependent on the guideway length without any specific requests being made
 *** The tolerance of the hole distances (LA) is in proportion to the length tolerance
 **** 5 BohrungsTypen der Schienen, jeweils für Schraubengröße T (nach untenstehender Zeichnung)
 ***** Special screw with reduced diameter. Please contact us.

5

M AND ML GUIDEWAYS WITH SLIDING LAYER (TURCITE OR PERMAGLIDE)



A MATERIAL

M and ML guideways: non-hardened tool steel 1.2842 with affixed Turcite (LB) or Permagliding (LP21)- sliding layer.

C CHOICE OF COATING

Reference values	Layer	
	Turcite LB	Permagliding LP21
Specific permissible load capacity Static p_{max} [N/mm ²]	6	250
$p * v_{max}$ [N/mm ² * m/s]	1	3
Permissible temperature [°C]	-40° bis +80°	-40° bis +110°
Friction coefficient (without lubricant)	0.15 – 0.26	Not usable
Friction coefficient (with lubricant)	0.04 – 0.08	0.02 – 0.2

IMPORTANT INFORMATION

The use of M and ML guideway sets with a sliding layer and V guideways (without clearance or preloaded) in a rigid environment can result in uncontrolled friction in the presence of thermal expansion.

B QUALITY

The guideways with a sliding layer are available in 2 qualities (parallelism tolerance of the raceways on the reference sides of the guideways in relation to a defined length).

Q10: normal quality for general machine construction
 Q6: precise quality for machine tool construction

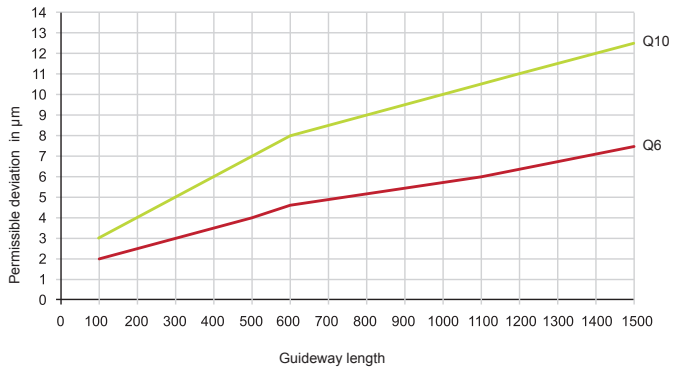

SPECIAL EXECUTIONS
 SEE CHAPTER 10 ALTERNATIVE VERSIONS

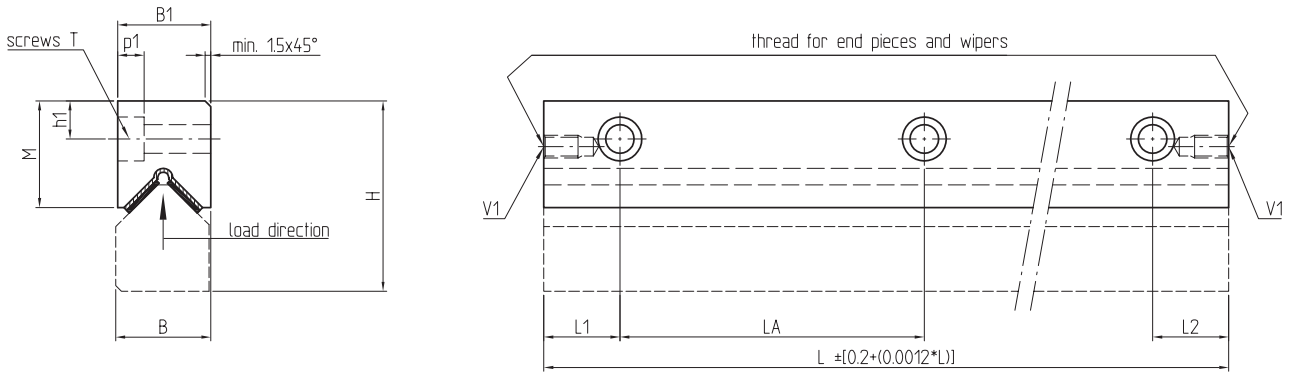

DIMENSIONS IN (MM)

Type	External dimensions					Fixing holes											Threads
	H 0/-0.2	B 0/-0.1	B1 0/-0.2	M	V	Screws T ****	d	f	h	h1	p1 min.	t min.	LA***	L1** min.	L2** min.	V1	
M3015	30	15	15	15.75	-	M4	8.5	5.25	M4	5.5	4.6	15	40*	15	15	M3	
V3015				-	10.5												
M4020	40	20	20	22.5	-	M6	11.5	7.5	M6	7.5	6.9	20	80*	15	15	M5	
V4020				-	13.5												
M5025	50	25	25	28	-	M6	11.5	7.5	M6	10	6.9	15	80*	20	20	M6	
V5025				-	17												
M6035	60	35	35	35	-	M8	15	10	M8	11	9.1	20	100	20	20	M6	
V6035				-	20												
M7040	70	40	40	40	-	M10	18.5	12.5	M10	13	11.1	25	100	20	20	M6	
V7040				-	24												
M8050	80	50	50	45	-	M12	20	14	M12	14	13.1	30	100	20	20	M6	
V8050				-	26												

* M3015: length (L) 100mm, hole distances (LA) = 35mm
M4020: length (L) 100mm, hole distances (LA) = 50mm
M5025: length (L) 100mm, hole distances (LA) = 50mm

** L1 and L2 are the same size at both ends of the guideways and dependent on the guideway length without any specific requests being made.

*** The tolerance of the hole distances (LA) is in proportion to the length tolerance

**** 4 hole types in the guideways for screw size T (according to the drawing below)

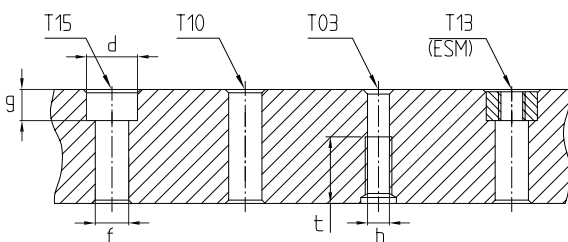

T15: Sinkhole for screws ISO 4762
T10: Clearance hole
T03: Threaded hole, thread length "t"
T13: Sinkhole as T15, but with insert nuts ESM

STANDARD LENGTHS (MM)

MAXIMUM PERMISSIBLE STATIC LOAD*

	100	150	200	300	400	500	600	700	800	900	1000	L/max	Turcite LB (N)	Permaglide LP21 (N)
	●	●	●	●	●	●	●					600	3'600	150'000
	●	●	●	●	●	●	●	●	●	●	●	1'000	6'600	275'000
	●		●	●	●	●	●	●	●	●	●	1'300	8'400	350'000
			●	●	●	●	●	●	●	●	●	1'300	12'000	500'000
			●	●	●	●	●	●	●	●	●	1'300	13'800	575'000
			●	●	●	●	●	●	●	●	●	1'300	16'200	675'000

● = Standard lengths
Special lengths available on request

* For guideways with a length of 100 mm, load direction according to dimension diagram, see page 58

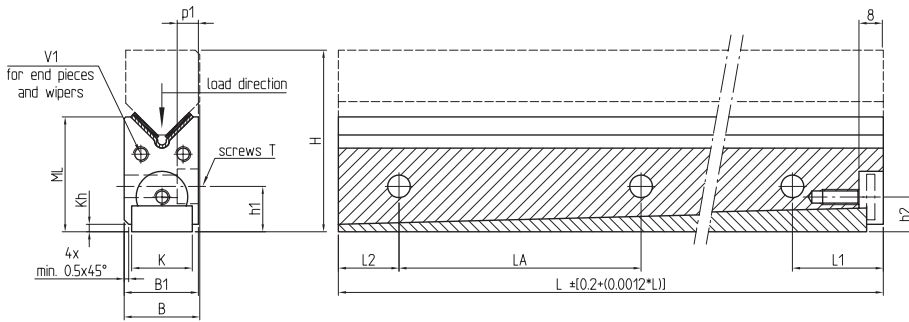

DIMENSIONS (MM)

Type	External dimensions						Fixing holes										Threads
	H 0/-0.2	B 0/-0.1	B1 0/-0.2	ML*	K	Kh*	Screws T ****	d	f	h	h1	p1 min.	t min.	LA***	L1** min.	L2** Min.	
ML5020	50	20	20	33	15	5.5	M6	11.5	7.5	M6	17.5	4.6	20	8	30	15	M4
ML5520	55	20	20	38	15	6	M6	11.5	7.5	M6	22.5	5.2	20	80	30	15	M4
ML5525	55	25	25	34	20	2.5	M6	11.5	7.5	M6	15	6.9	15	80	30	20	M5
ML6025	60	25	25	39	20	3.5	M6	11.5	7.5	M6	20	6.9	15	80	30	20	M5
ML6525	65	25	25	44	20	5	M6	11.5	7.5	M6	25	6.9	15	80	30	20	M5
ML7025	70	25	25	48	20	6.5	M6	11.5	7.5	M6	30	6.9	15	80	30	20	M5
ML7035	70	35	35	45.5	25	3	M8	15	10	M8	21	6.9	20	100	32	20	M6
ML8035	80	35	35	55.5	25	5	M8	15	10	M8	31	9.1	20	100	32	20	M6
ML8040	80	40	40	50.5	30	3	M10	18.5	12.5	M10	23	9.1	25	100	32	20	M6
ML9040	90	40	40	60.5	30	5	M10	18.5	12.5	M10	33	9.1	25	100	32	20	M6
ML9050	90	50	50	56	40	3	M12	20	14	M12	24	11.1	30	100	32	20	M6
ML10050	100	50	50	66	40	5	M12	20	14	M12	34	11.1	30	100	32	20	M6

* These dimensions are dependent on the gib position, adjustment range ± 0,5 mm
 ** ML5020 + ML5525 + ML7035 + ML8040 + ML9050: length (L) 100mm, hole distance (LA) = 50mm.
 *** L1 and L2 are the same size at both ends of the guideways and dependent on the guideway length without any specific requests being made.
 **** 3 hole types in the guideways for screw size T (according to the drawing below)

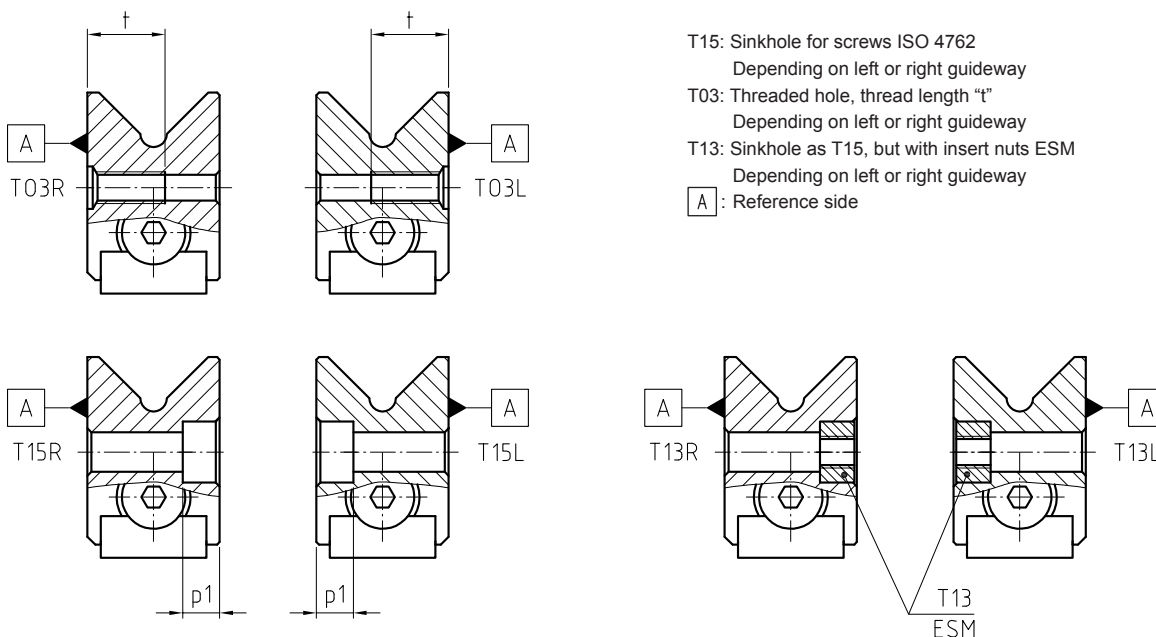

T15: Sinkhole for screws ISO 4762
 Depending on left or right guideway
 T03: Threaded hole, thread length "t"
 Depending on left or right guideway
 T13: Sinkhole as T15, but with insert nuts ESM
 Depending on left or right guideway
 [A]: Reference side

STANDARD LENGTHS (MM)

MAXIMUM PERMISSIBLE STATIC LOAD*

STANDARD LENGTHS (MM)											MAXIMUM PERMISSIBLE STATIC LOAD*		
100	200	250	300	400	500	600	700	750	800	900	1000	Turcite LB (N)	Permaglide LP21 (N)
●	●		●									6'600	275'000
				●	●	●						6'600	275'000
●	●	●										8'400	350'000
			●	●	●							8'400	350'000
						●	●	●				8'400	350'000
									●	●	●	8'400	350'000
●	●		●	●	●							12'000	500'000
						●	●		●	●	●	12'000	500'000
●	●		●	●	●							13'800	575'000
						●	●		●	●	●	13'800	575'000
●	●		●	●	●							16'200	675'000
						●	●		●	●	●	16'200	675'000

● = Standard lengths
Special lengths available on request

* For guideways with a length of 100mm, load direction according to dimension diagram, see page 60

6

S AND J GUIDEWAYS WITH NEEDLE ROLLER FLAT CAGE ASSEMBLY



A MATERIAL

Hardened tool steel 1.2842 HRc 58 – 62.

B QUALITY

The raceways and locating faces are precision ground.

The guideways are available in 3 qualities (parallelism tolerance of the raceways on the reference sides of the guideway in relation to a defined length).

IMPORTANT INFORMATION

The correct functioning of the guideways is dependent above all on the precision of the locating faces.

MATCHING IN SETS

Matching in sets “M/V/S/J” (4SX) when an order is placed allows for installation without insert plate or ML guideway. The guideways are labelled by sets. The tolerance of the height difference must be maintained with the connecting parts in this case.

Q10: normal quality for general machine construction

Q6: precise quality for machine tool construction

Q2: particularly precise quality for exceptionally demanding structures

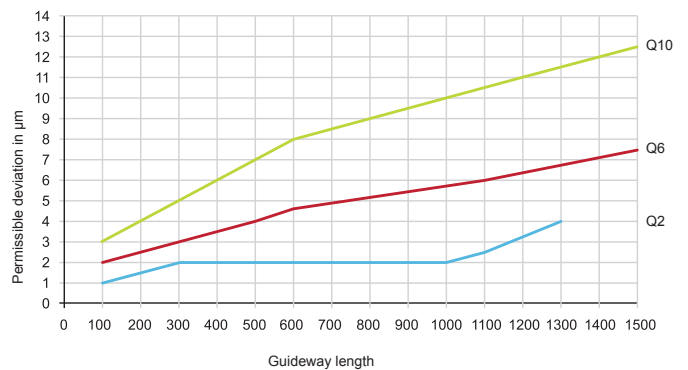

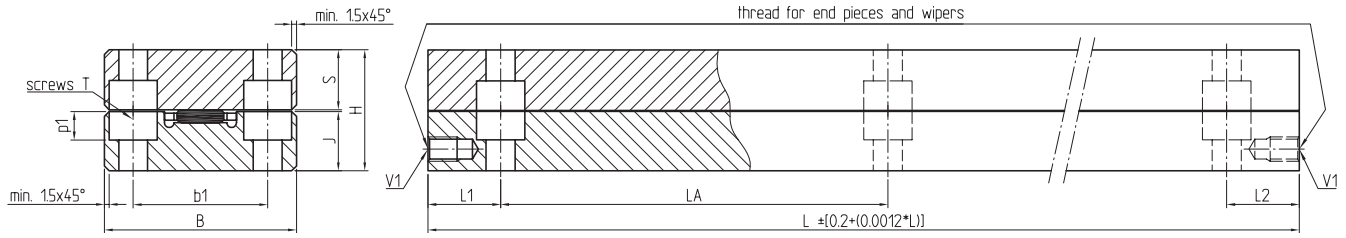

DIMENSIONS IN (MM)

Type	External dimensions				Fixing holes										Threads
	H 0/-0.2	B 0/-0.2	S	J	Screws T ****	d	f	h	b1	p1	p1 min.	LA***	L1*** min.	L2** min.	V1
S3525	25	35	13	-	M5	10.5	6.25	M6	22	(5.8)	(5.7)	80*	15	15	-
J3525			-	11.8											M5
S4025	25	40	12.5	-	M5	10.5	6.25	M6	28	(5.8)	(5.7)	80*	15	15	-
J4025			-	12.3											M5
S5030	30	50	15	-	M6	11.5	7.5	M6	35	(6.9)	(6.8)	100*	15	15	-
J5030			-	14.8											M6
S5530	30	55	14.5	-	M6	11.5	7.5	M6	40	(6.9)	(6.8)	100*	15	15	-
J5530			-	15.3											M6

* S/J3525: length (L) 100mm, hole distances (LA) = 50mm
 S/J4025: length (L) 100mm, hole distances (LA) = 50mm
 S/J5030: length (L) 100mm, hole distances (LA) = 50mm
 S/J5530: length (L) 100mm, hole distances (LA) = 50mm

** L1 and L2 are the same size at both ends of the guideway and dependent on the guideway length without any specific requests being made.

*** The tolerance of the hole distances (LA) is in proportion to the length tolerance

**** 2 hole types in the guideways for screw size T (according to the drawing below)

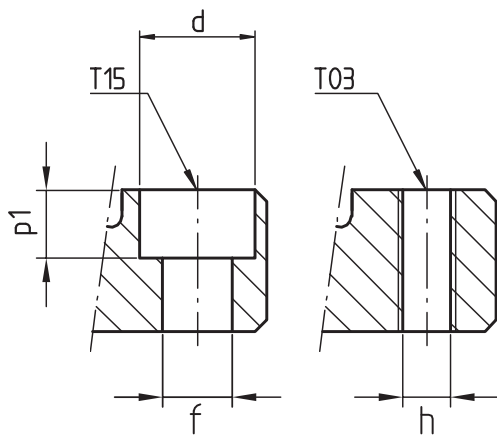

T15: Sinkhole for screws ISO 4762
 T03: Threaded hole

STANDARD LENGTHS (MM)

CAGE ALLOCATION

1 0 0	2 0 0	3 0 0	4 0 0	5 0 0	6 0 0	7 0 0	8 0 0	9 0 0	1 0 0 0	L/max	Rolling elements	Plastic	Aluminium	Steel	Brass	Brass (with damping)
●	●	●	●	●	●	●	●	●	●	1'300	Rolling elements	E-FF2010	E-H10	E-H10 F	E-H10 MS	E-HG10
●	●	●	●	●	●	●	●	●	●	1'300	Needle rollers or balls	E-FF2515	E-H15 E-HB2515	E-H15 F	E-H15 MS	E-HG15
●	●	●	●	●	●	●	●	●	●	1'300	Needle rollers or balls	E-FF3020	E-H20 E-HB3020			E-HG20
●	●	●	●	●	●	●	●	●	●	1'300	Needle rollers or balls	E-FF3525	E-H25 E-HB4025	E-H25 F	E-H25 MS	E-HG25

Further information can be found in the chapter Linear Cages.

● = Standard lengths
 Special lengths available on request

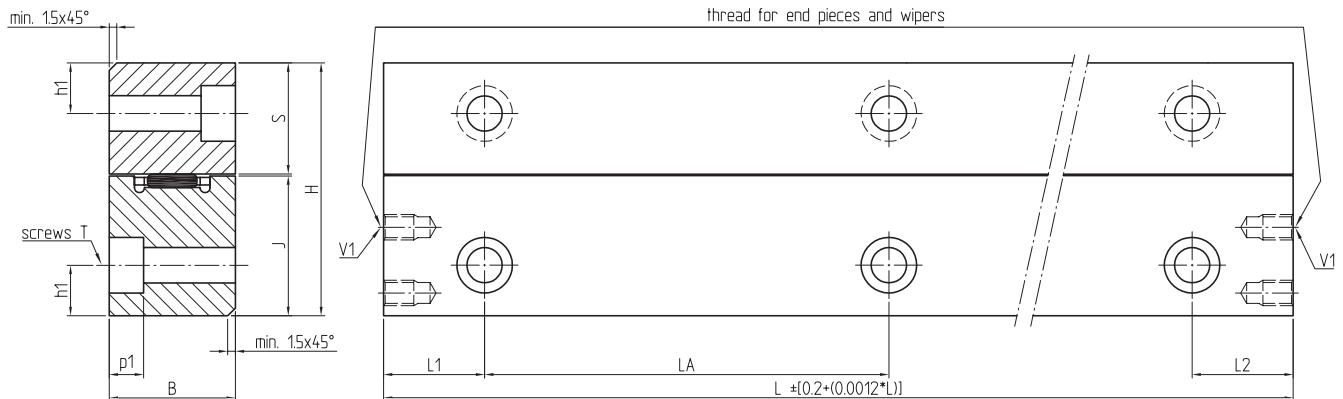

DIMENSIONS IN (MM)

Type	External dimensions				Fixing holes									Threads	
	H 0/-0.2	B 0/-0.2	S	J	Screws T ****	d	f	h	p1 min.	t min.	LA***	L1** min.	L2** min.	V1	
S5025	50	25	22	-	M6	11,5	7,5	M6	(6.8)	15	80*	20	20	-	
J5025			-	27.7										M6	
S6035	60	35	25	-	M8	15	10	M8	(9)	20	100*	20	20	-	
J6035			-	34.7										M8	M6
S7040	70	40	30	-	M10	18,5	12,5	M10	(11)	25	100*	20	20 20	-	
J7040			-	39.7										M10	M6
S8050	80	50	35	-	M12	20	14	M12	(13)	30	100*	20	20	-	
J8050			-	44.7										M12	M6

* S/J5025: length (L) 100mm, hole distances (LA) = 50mm
 S/J6035: length (L) 100mm, hole distances (LA) = 50mm
 S/J7040: length (L) 100mm, hole distances (LA) = 50mm
 S/J8050: length (L) 100mm, hole distances (LA) = 50mm

** L1 and L2 are the same size at both ends of the guideway and dependent on the guideway length without any specific requests being made

*** The tolerance of the hole distances(LA) is in proportion to the length tolerance

**** 2 hole types in the guideways for screw size T (according to the drawing below)

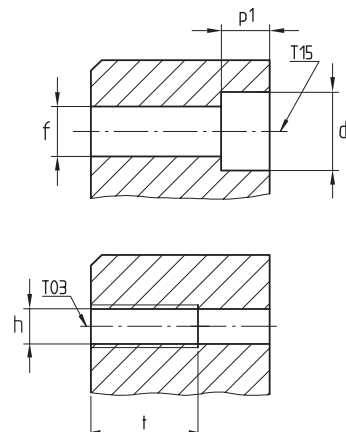

T15: Countersunk hole for screws ISO 4762
 T03: Threaded hole, thread length "t"

STANDARD LENGTHS (MM)

CAGE ALLOCATION

	1 0 0	2 0 0	3 0 0	4 0 0	5 0 0	6 0 0	7 0 0	8 0 0	9 0 0	1 0 0 0	L/max	Rolling elements	Plastic	Aluminium	Steel	Brass	Brass (with damping)
	●	●	●	●	●	●	●	●	●	●	1'000	Needle rollers	E-FF2515	E-H15 AL	E-H15 F	E-H15 MS	E-HG15
	●	●	●	●	●	●	●	●	●	●	1'000	Needle rollers or balls	-	E-H24 ZW	E-H24 ZW F	E-H24 ZW MS	-
	●	●	●	●	●	●	●	●	●	●	1'300	Needle rollers or balls	-	E-H34 ZW	E-H34 ZW F	E-H34 ZW MS	-
	●	●	●	●	●	●	●	●	●	●	1'300	Needle rollers or balls	-	E-H44 ZW	E-H44 ZW F	E-H44 ZW MS	-

Further information can be found in the chapter Linear Cages.

● = Standard lengths
 Special lengths available on request

7

LUE – COUNTERSTAY SYSTEM WITH NEEDLE AND CYLINDRICAL ROLLER FLAT CAGE ASSEMBLIES

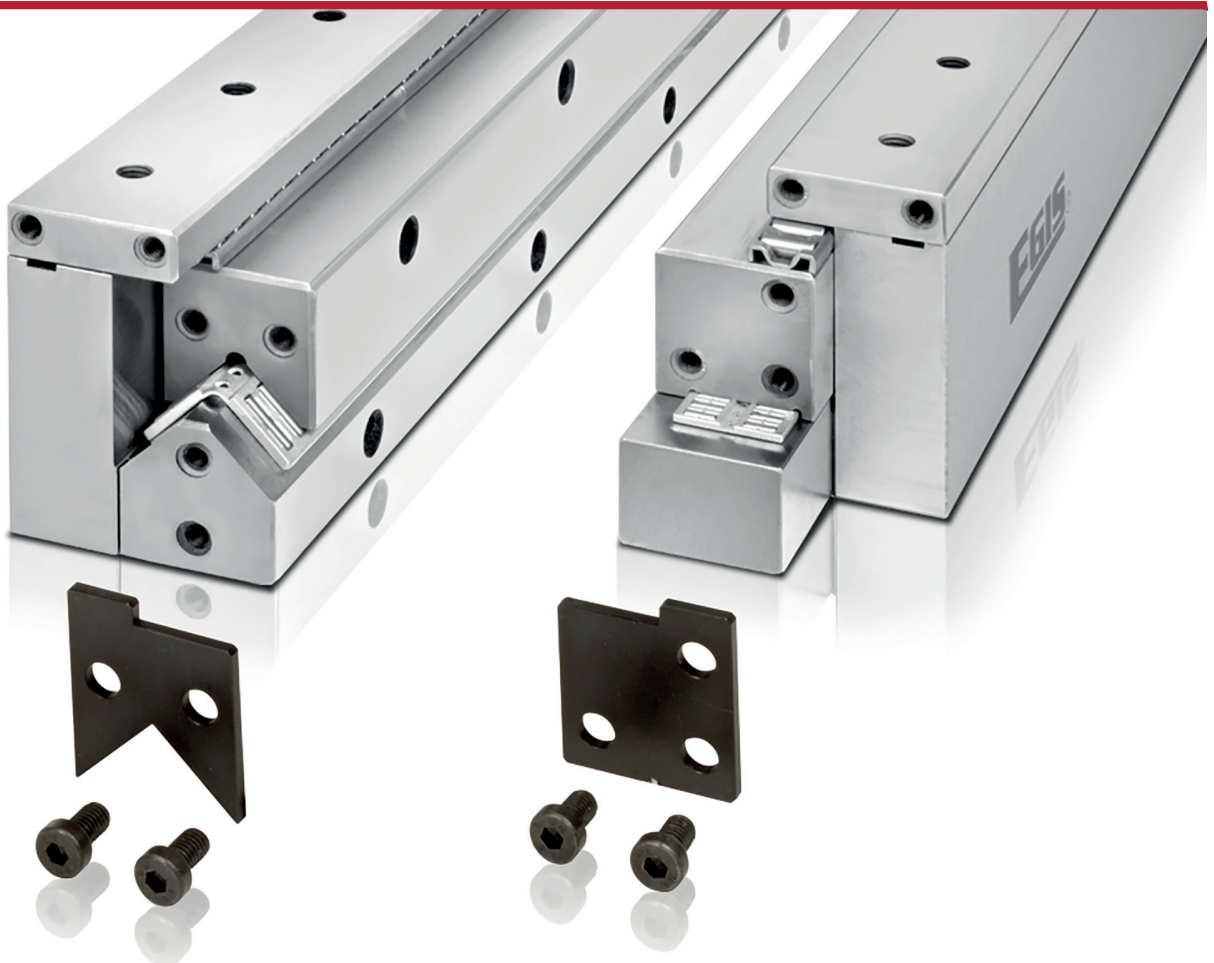

The LUE counterstay system is particularly suited to high-precision applications. This system provides the highest level of accuracy of all linear guidance systems with rolling elements. It is the perfect solution when a high degree of accuracy and rigidity are required, particularly when the main load operates in a vertical or lateral direction. The separation between locating and non-locating bearings prevents the system from becoming distorted by thermal expansion.

The LUE counterstay system does not require any adjustment after assembly.

The system is preloaded by components which have been adjusted against one another in terms of dimensions. Preloading is established by observing the prescribed tightening torques during assembly without any adjustments being required.

A MATERIAL

M and V and S and J guideways: Hardened tool steel 1.2842 HRc 58 – 62

LU counterstays: counterstay bar (LUT) made from hardened tool steel 1.2842 HRc 58 – 62 and a distance bar (LUD) made from soft construction steel.

B QUALITY

The raceways and locating faces are precision ground.

Q2: particularly precise quality for exceptionally demanding structures

The LUE counterstay system is only supplied in Q2 quality, which is the highest quality for standard guideways (parallelism tolerance of the raceways to the reference sides of the guideways in relation to a defined length).

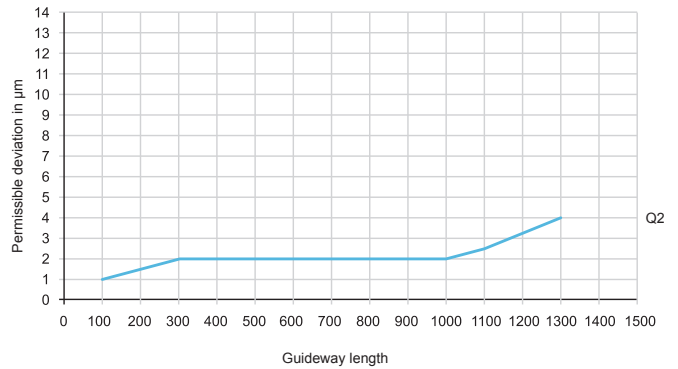

SPECIAL EXECUTIONS
SEE CHAPTER 10 ALTERNATIVE VERSIONS

C MATCHING IN SETS

The guideways are manufactured, labelled and packaged by sets.

NB

Under no circumstances must the counterstay components be mixed up as matching and preloading could no longer be guaranteed in that case.

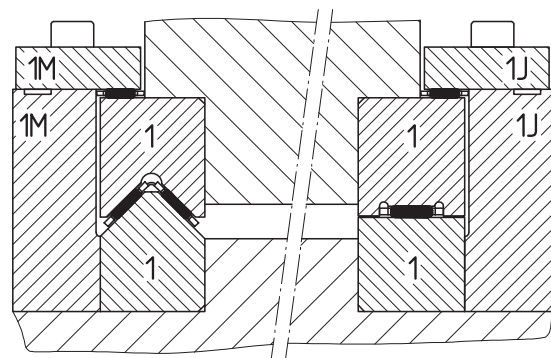

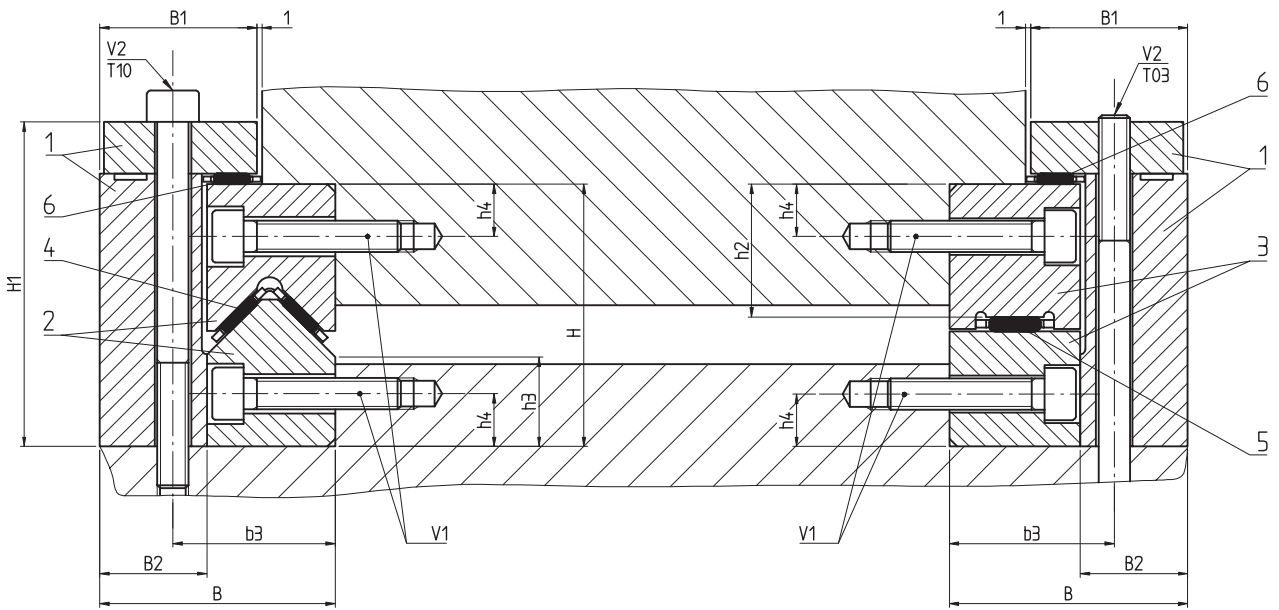

DIMENSIONS IN (MM)

Type	External dimensions						Fixing holes							L/max		
	H 0/-0.2	H1	B	B1	B2	b3	V1	V2	Tightening torque (Nm)	h2	h3	h4	LA** LU	L1* min.	L2* min.	LU
LUE 5025	50	62	45	30	20	31	M6	M6	12	25.5	17	10	50	20	20	800
LUE 6035	60	77	60	40	25	42	M8	M8	29	33	20	11	50	20	20	1'000
LUE 7040	70	89	65	40	25	47	M10	M8	58	37.5	24	13	50	20	20	1'000
LUE 8050	80	100	86	51	36	61	M12	M12	101	42	26	14	50	20	20	1'000

H of M&V and H of S&J paired within the same 5 micrometers.

All cages have matching needle diameters.

* L1 and L2 are the same size at both ends of the guideway and dependent on the guideway length without any specific requests being made.

** The tolerance of the hole distances (LA) is in proportion to the length tolerance

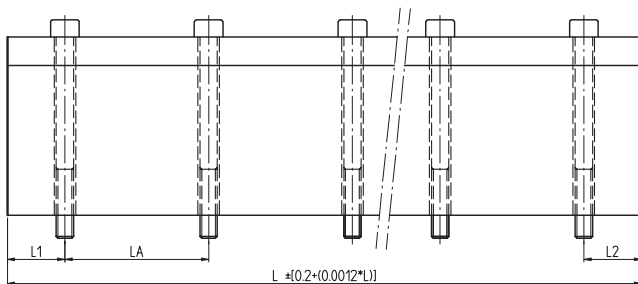

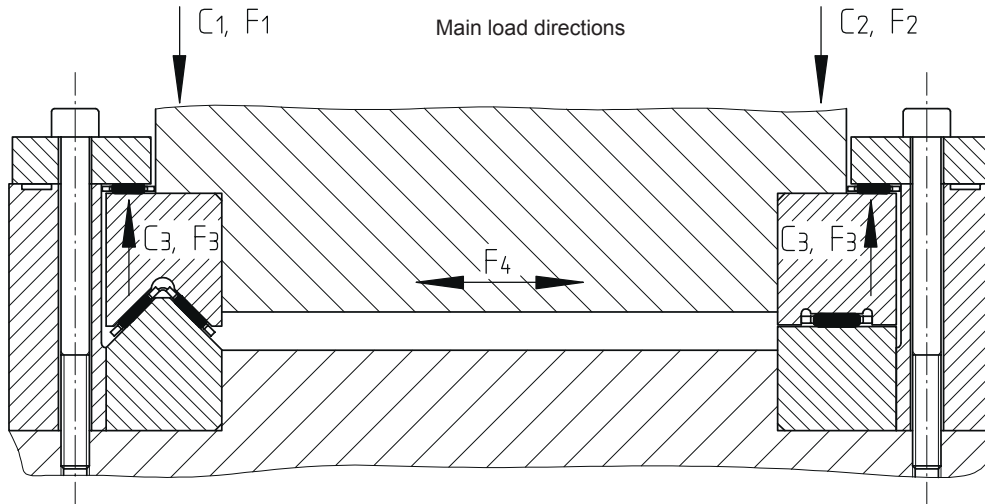

LUE - COUNTERSTAY SYSTEM COMPONENTS

LOAD CARRYING CAPACITY

Counterstays	Guideways M/V	Guideways S/J	Precision cage: G1			Basic dynamic load ratings			Limiting loads*			
			Pos. 4	Pos. 5	Pos. 6	C ₁ (N)	C ₂ (N)	C ₃ (N)	F ₁ (N)**	F ₂ (N)**	F ₃ (N)***	F ₄ (N)***
LU5025	5025	5025	E-HW15	E-H15	E-H10	25'960	35'620	21'410	13'840	15'630	1'200	7'500
LU6035	6035	6035	E-HW20	E-H24 ZW	E-BF5015	40'200	36'710	70'410	38'690	58'620	1'500	10'000
LU7040	7040	7040	E-HW25	E-H34 ZW	E-BF5015	62'840	56'850	70'410	42'500	61'720	2'500	16'000
LU8050	8050	8050	E-HW30	E-H44 ZW	E-BF5015	82'980	88'860	70'410	43'150	69'540	4'000	23'000

All cages have matched needle diameters.

* For a theoretical cage length of 100 mm in load direction according to table (see above)
Calculation of limiting loads for effective cage lengths:

$$F_{w1,2,3} = F_{1,2,3} \cdot \frac{L_k - 2L1 + t}{100} \text{ where } Z = \frac{L_k - 2L1 + 1}{100} = \text{whole number}$$

** limited by system preload

*** limited by load carrying capacity / friction locking effect of fixing screws

8

FLAT CAGE ASSEMBLIES

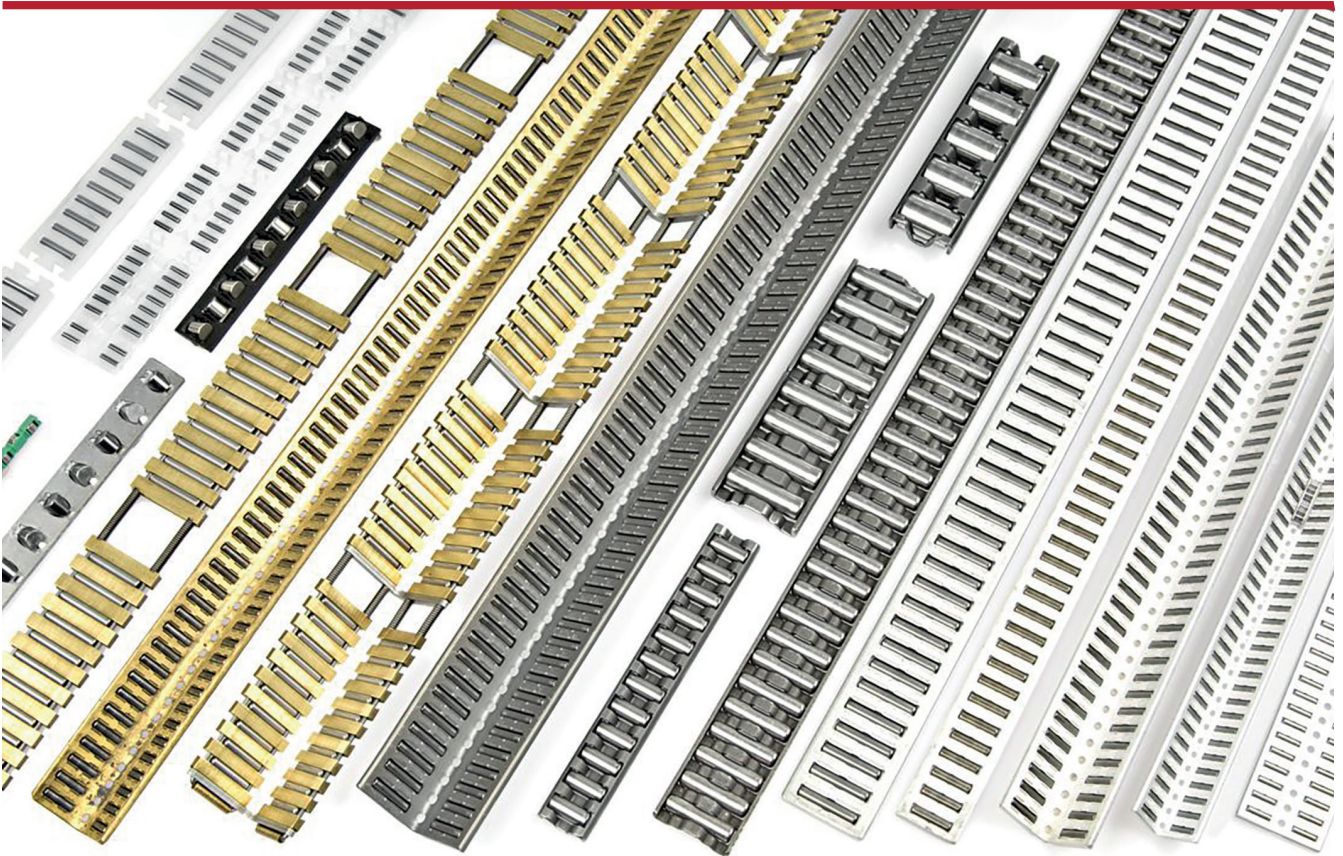

A GENERAL ASPECTS

Every cage type possesses specific technical characteristics and application features. The flat cage assemblies presented in the table below are intended for use with the guideways described in this catalogue. However, they can also run directly on raceways in connecting parts which fulfil the necessary characteristics.

The cage length can be adapted to the application in steps according to the spacing LA.

C MATERIAL

4 materials for flat basic cages:

- Aluminium (standard) for normal operating conditions and high accelerations
- Steel for difficult operating conditions (suffix "F")
- Plastic for easy operating conditions (series E-FF / E-FFW)
- Brass for special operating conditions (suffix "MS") (Standard for cages with damping)

B RACEWAY CHARACTERISTICS

The raceways must fulfil the same conditions as the raceways on the guideways

- Surface roughness $R_a \leq 0.35 \mu\text{m}$
- Hardness min. 58 HRC / 670 HV

(with lower hardness levels, the hardness factors according to figure 10 page 23 should be taken into account)

D ALTERNATIVE VERSIONS

- Higher precision of rolling elements (suffix G1)
- Corrosion-resistant cages (suffix BK)
- Friction-reducing coating (suffix BR)

DELIVERABLE CAGES

Flat cage material	Rolling elements			
	Type	Cage shape	Single row	Double row
Plastic	Needle rollers	Flat	E-FF	E-FF...ZW
		Angled		E-FFW
Aluminium	Needle rollers	Flat	E-H	E-H ZW
		Angled		E-HW
	Cylindrical rollers	Flat	E-HR	E-HR ZW
		Angled		E-HRW
	Balls	Flat	E-HB	
		Angled		E-HBW
Steel	Needle rollers	Flat	E-H F	E-H ZW F
		Angled		E-HW F
		Profiled sheet	E-BF	
Brass	Needle rollers	Flat	E-H MS	E-H ZW MS
		Angled		E-HW MS
	Needle rollers with damping	Flat	E-HG	
		Angled		E-HGW

ACCURACY OF THE ROLLING ELEMENTS

Rolling elements	According to DIN standard	Quality category	Roundness μm	Category tolerance μm
Needle rollers	DIN 5402-3	G2 (standard)	1	2
		G1	0.5	1
Cylindrical rollers	DIN 5402-1	G2	1	2
		G1	0.5	1
Balls	DIN 5401	G5	0.13	1

E SINGLE-ROW FLAT CAGE ASSEMBLIES

E-FF

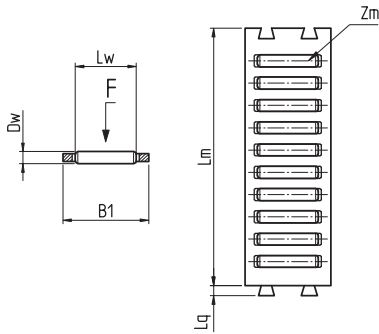

E-H, E-BF, E-H F, E-H MS

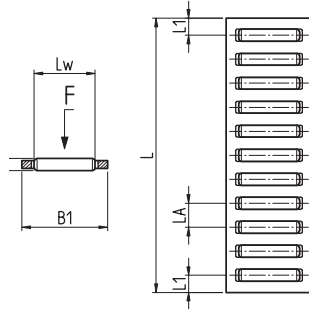

E-HR

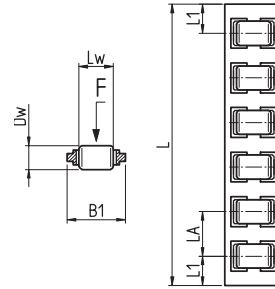

F = Load direction

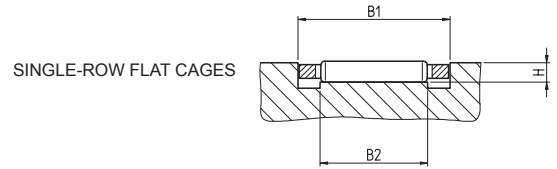

DIMENSIONS IN (MM)

Rolling element diameter	Type				Dimensions							Number of rolling element per row	Basic load ratings **		Mounting dimensions (mm)		
	E-FF	E-H E-H F E-H MS	E-BF	E-HR	B1	Lw	LA	L1	Lq	L* max.	Lm		Zm	C N	Co N	B1	B2 min.
2	E-FF2010				10	6.8			2		32	7	21'160	61'900	10.3 ^{+0.2/0}	7	1.7
		E-H10			10	6.8	4.5	3.5		2'000			21'410	62'900			
2.5	E-FF2515				15	9.8			2.5		45	8	32'600	92'300	15.3 ^{+0.2/0}	10	2.2
		E-H15			15	9.8	5	3.5		2'000			35'620	103'900			
3	E-FF3020				20	13.8			3		60	9	47'880	133'300	20.4 ^{+0.2/0}	14	2.7
		E-H20			20	13.8	6	4.5		2'000			51'830	148'100			
			E-BF3020		20	15.8	6	4.5		2'000			57'750	170'200			
3.5	E-FF3525				25	17.8			3		75	10	64'990	177'400	25.4 ^{+0.2/0}	18	3.2
		E-H25			25	17.8	7	5		2'000			68'450	190'100			
5				E-HR50	10.5	5	10	6.5		2'000			29'400	50'800	10.9 ^{+0.2/0}	5	3.4
			E-BF5015		15	11.8	8	5.5		2'000			70'410	154'700	23.4 ^{+0.2/0}	12	
			E-BF5023		23	19.8	8	5.5		2'000			107'080	265'200	23.4 ^{+0.2/0}	20	4.6
			E-BF5032		32	27.8	8	5.5		2'000			140'400	375'700	32.5 ^{+0.3/0}	28	
7				E-HR70	17	10	13	8.5		2'000			65'800	114'200	17.4 ^{+0.2/0}	10	4.8
			E-BF7028		28	24	11	7.5		2'000			153'000	331'900	28.4 ^{+0.2/0}	24	6.5
			E-BF7035		35	30	11	7.5		2'000			182'480	416'300	35.6 ^{+0.3/0}	30	
10			E-HR100	24	14	17	10		2'000			109'900	174'200	24.4 ^{+0.2/0}	14	6.5	
12			E-BF12022		22	18	16	10		2'000			183'000	288'400	22.4 ^{+0.2/0}	18	11
			E-BF12040		40	36	16	10		2'000			317'950	586'800	40.5 ^{+0.3/0}	36	

* Length tolerance: 0/-1*LA

** Basic load ratings for a theoretical cage length of 100mm in load direction "F"

F DOUBLE-ROW FLAT CAGE ASSEMBLIES

E-FF ZW

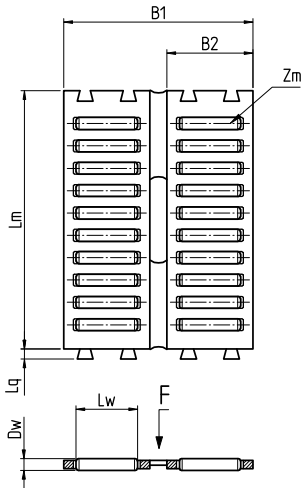

E-H ZW, E-H ZW F, E-H ZW MS

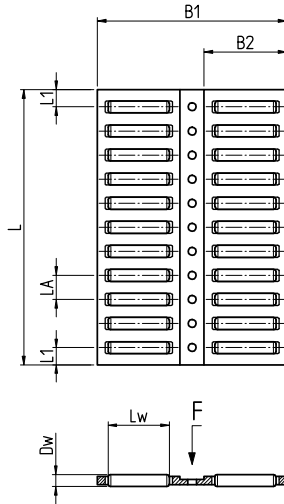

E-HR ZW

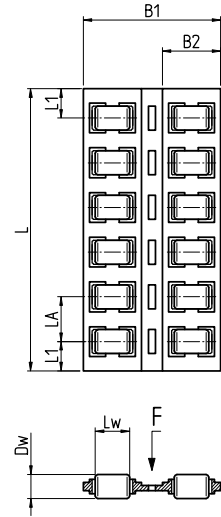

F = Load direction

DOUBLE-ROW FLAT CAGES

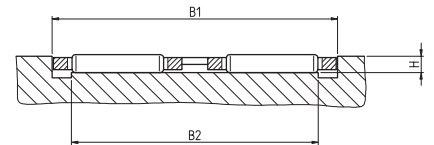

DIMENSIONS IN (MM)

Rolling element diameter	Type			Dimensions									Number of rolling element per row	Basic load ratings **		Mounting dimensions (mm)		
	E-FF ZW	E-H ZW E-H ZW F E-H ZW MS	E-HR ZW	B1*	B2	Lw	LA	L1	Lq	L** max.	Lm	Zm		C N	Co N	B1	B2 min.	H
2		E-H19 ZW F		19.2	8	4.8	4	3		1'000			29'960	97'200	19.6 ^{+0.20}	17	1.7	
	E-FF2025 ZW			25	10	6.8			2		32	7	36'280	123'800	25.4 ^{+0.20}	22		
2.5		E-H24 ZW		24	10.5	6.8	4.5	3.5		2'000			36'710	125'700	24.4 ^{+0.20}	21	2.2	
	E-FF2535 ZW			35	15	9.8			2.4		45	8	55'900	184'700	35.5 ^{+0.20}	30		
3		E-H34 ZW		33.5	14.3	9.8	5.5	4		2'000			56'850	188'900	34.0 ^{+0.20}	28.5	2.7	
	E-FF3045 ZW			45	20	13.8			3		60	9	82'090	266'500	45.5 ^{+0.20}	39		
3.5		E-H44 ZW		44	19	13.8	6	4.5		2'000			88'860	296'100	44.5 ^{+0.20}	38	3.2	
	E-FF3555 ZW			55	25	17.8			3.2		75	10	111'420	354'800	55.5 ^{+0.20}	48		
5			E-HR50 ZW	24	10.5	5	10	6.5		2'000			51'080	101'700	24.4 ^{+0.20}	19.5	3.4	
7			E-HR70 ZW	40	17	10	13	8.5		2'000			114'900	228'500	40.5 ^{+0.20}	34	4.8	
10			E-HR100 ZW	55	24	14	17	10		2'000			193'110	348'400	55.5 ^{+0.20}	46	6.5	

* Length tolerance: 0/-1*LA

** Basic load ratings for a theoretical cage length of 100mm in load direction "F"

G ANGLED FLAT CAGE ASSEMBLIES

E-FFW

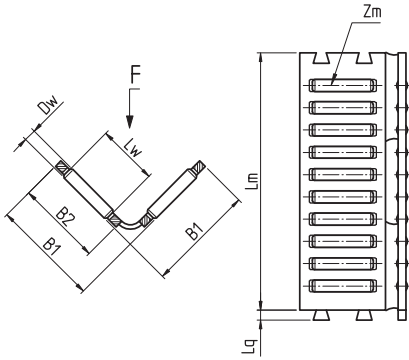

E-HW, E-HW F, E-HW MS

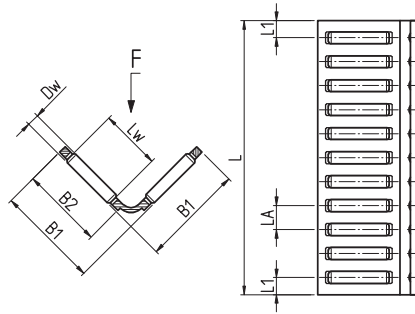

E-HRW

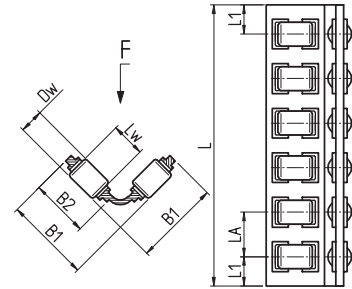

F = Load direction

DIMENSIONS IN (MM)

Rolling element diameter	Type			Dimensions								Number of rolling element per row	Rolling element diameter *	
	E-FFW	E-HW E-HW F E-HW MS	E-HRW	B1	B2	Lw	LA	L1	Lq	L* max.	Lm		Zm	C N
2		E-HW10 F		10	8	4.8	4	3		1'000			21'190	68'800
	E-FFW2025			15	10	6.8			2		32	7	25'650	87'500
		E-HW15		14	10.5								25'960	88'900
		E-HW16		16	13.5	8.8	4.5	3.5		2'000			36'410	138'200
2.5	E-FFW2535			20.5	15	9.8			2.4		45	8	39'530	130'600
		E-HW20		20	14.3		5.5	4		2'000			40'200	133'500
3	E-FFW3045			26	20	13.8			3		60	9	58'050	188'500
		E-HW25		25	19		6	4.5		2'000			62'840	209'400
3.5	E-FFW3555			31.5	25	17.8			3.2		75	10	78'790	250'900
		E-HW30		30	24		7	5		2'000			82'980	26'880
5			E-HRW50	15.5	10.5	5	10	6.5		2'000			36'120	71'900
7			E-HRW70	25	17	10	13	8.5		2'000			81'240	161'600
10			E-HRW100	34	24	14	17	10		2'000			136'550	246'400

* Length tolerance: 0/-1*LA

** Basic load ratings for a theoretical cage length of 100mm in load direction "F"

H BALL FLAT CAGE ASSEMBLIES

E-HB

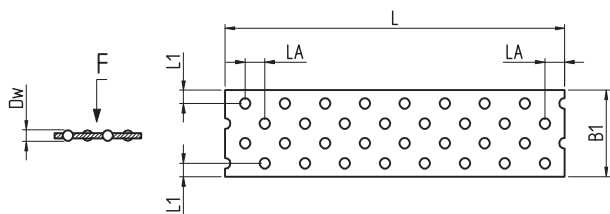

E-HBW

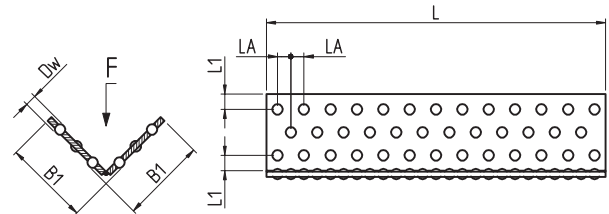

F = Load direction

DIMENSIONS IN (MM)

Ball diameter	Type		Dimensions				Basic load ratings**	
	E-HB	E-HBW	B1	LA	L1	L* max.	C N	Co N
2.5	E-HB2515		15	3	4.5	2'000	3'180	3'040
3	E-HB3020		20	3.5	4	2'000	5'140	5'000
		E-HBW3x18x18	17.75	3.5	3.5	1'000	5'970	5'020
	E-HB3023		23	3.5	5.5	2'000	5'140	5'000
		E-HBW3x23x23	22.75	3.5	4	1'000	7'300	6'690
4	E-HB4025		25	5	5	2'000	7'410	6'220

* Length tolerance: 0/-1*LA

** Basic load ratings for a theoretical cage length of 100mm in load direction "F"

FLAT CAGE ASSEMBLIES WITH DAMPING

E-HG

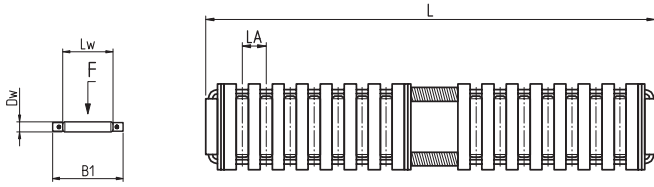

E-HGW

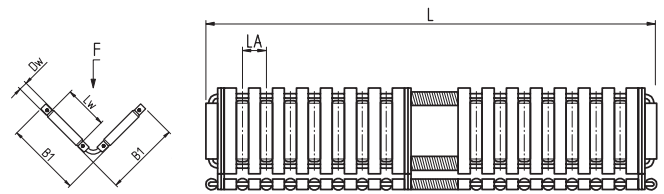

F = Load direction

DIMENSIONS IN (MM)

Rolling element diameter	Type		Dimensions				Basic load ratings**		Dampig power
	E-HG	E-HGW	B1*	Lw	LA	L max.	C N	Co N	RS*** N
2	E-HG10		10	6.3	4.5	2000	18'210	50'800	0.5
		E-HGW15	13.5			1500	21'760	70'500	9
2.5	E-HG15		15	9.8	5	2000	31'630	88'700	8
		E-HGW20	19.5			1500	37'970	123'800	16
3	E-HG20		20	13.8	6	2000	47'780	132'900	1
		E-HGW25	25			1500	57'370	185'500	22
3.5	E-HG25		25	17.8	7	2000	61'740	165'700	14
		E-HGW30	30.5			1500	74'320	232'100	28

* Mounting dimensions: see table page 76

** Basic load ratings for a theoretical cage length of 100mm in load direction "F"

*** For a cage length of 100mm.

Calculation of the damping power for the effective cage length =>RSw=RS* $\frac{L}{100}$

K DELIVERABLE CAGE ASSEMBLIES

Flat cage material	Rolling elements	Cage shape	Number of rows	Designation	Dimensions	Weight per meter (g)	Guideway allocation		
Plastic	Needle rollers	Flat	1	E-FF	E-FF2010	46	S3525, J3525		
					E-FF2515	84	S4025, J4025, S5025, J5025		
					E-FF3020	148	S5030, J5030		
					E-FF3525	221	S5530, J5530		
		Flat	2	E-FF ZW	E-FF2025 ZW	94	Special rails		
					E-FF2535-ZW	182	Special rails		
					E-FF3045-ZW	315	Special rails		
					E-FF3555-ZW	464	Special rails		
		Angled	2	E-FFW	E-FFW2025	94	M4020, V4020, M4422, V4422, M5025, V5025, M5225, V5225, ML5020, ML5520, ML5525, ML6025, ML6525, ML7025		
					E-FFW2535	182	M6035, V6035, M6230, V6230, ML7035, ML8035		
					E-FFW3045	315	M7040, V7040, M7435, V7435, ML8040, ML9040		
					E-FFW3555	464	M7845, V7845, M8050, V8050, ML9050, ML10050		
		Aluminium	Needle rollers	Flat	1	E-H	E-H10	63	S3525, J3525, LUE5025
E-H15	120						S4025, J4025, S5025, J5025, LUE5025		
E-H20	202						S5030, J5030		
E-H25	294						S5530, J5530		
Flat	2			E-H ZW	E-H24ZW	138	S6035, J6035, LUE6035		
					E-H34ZW	239	S7040, J7040, LUE7040		
					E-H44ZW	408	S8050, J8050, LUE8050		
					E-H55ZW	598	Special rails		
Angled	2			E-HW	E-HW10	105	M3015, V3015, M3115, V3115		
					E-HW15	138	M4020, V4020, M4422, V4422, M5025, V5025, M5225, V5225, ML5020, ML5520, ML5525, ML6025, ML6525, ML7025, LUE5025		
					E-HW16	190	M5025, V5025, M5225, V5225, ML5525, ML6025, ML6525, ML7025		
					E-HW20	239	M6035, V6035, M6230, V6230, ML7035, ML8035, LUE6035		
Angled	2		E-HW	E-HW25	408	M7040, V7040, M7435, V7435, ML8040, ML9040, LUE7040			
				E-HW30	598	M7845, V7845, M8050, V8050, ML9050, ML10050, LUE8050			
				Flat	1	E-HR	E-HR50	105	Special rails
							E-HR70	295	Special rails
E-HR100	598		Special rails						
Flat	2		E-HR ZW	E-HR50 ZW	215	Special rails			
				E-HR70 ZW	602	Special rails			
				E-HR100 ZW	1233	Special rails			
Angled	2		E-HRW	E-HRW50	215	M4525, V4525			
				E-HRW70	602	M6535, V6535			
				E-HRW100	1'233	M8550, V8550			
Balls	Flat		1	E-HB	E-HB2515	95	S4025, J4025, S5025, J5025		
		E-HB3020			167	S5030, J5030			
		E-HB3023			187	Special rails			
		E-HB4025			250	S5530, J5530			
	Angled	2	E-HBW	E-HBW3x18x18	300	Special rails			
				E-HBW3x23x23	480	Special rails			

Flat cage material	Rolling elements	Cage shape	Number of rows	Designation	Dimensions	Weight per meter (g)	Guideway allocation	
Steel	Needle rollers	Flat	1	E-H F	E-H10 F	127	S3525, J3525, LUE5025	
					E-H15 F	224	S4025, J4025, S5025, J5025, LUE5025	
					E-H20 F	369	S5030, J5030	
					E-H25 F	546	S5530, J5530	
		Profiled sheet	1	E-BF	E-BF3020	342	S5030, J5030	
					E-BF3015	375	LUE6035, LUE7040, LUE8050	
					E-BF5023	530	Special rails	
					E-BF5032	722	Special rails	
					E-BF7028	875	Special rails	
					E-BF7035	1'080	Special rails	
					E-BF12022	1'220	Special rails	
		Flat	2	E-H ZW F	E-BF12040	1'970	Special rails	
					E-H19 ZW F	219	Special rails	
					E-H24 ZW F	289	S6035, J6035, LUE6035	
					E-H34 ZW F	471	S7040, J7040, LUE7040	
					E-H44 ZW F	756	S8050, J8050, LUE8050	
		Angled	2	E-HW F	E-H55 ZW F	1'117	Special rails	
					E-HW10 F	219	M3015, V3015, M3115, V3115	
					E-HW15 F	289	M4020, V4020, M4422, V4422, M5025, V5025, M5225, V5225, ML5020, ML5520, ML5525, ML6025, ML6525, ML7025, LUE5025	
					E-HW20 F	471	M6035, V6035, M6230, V6230, ML7035, ML8035, LUE6035	
E-HW25 F	756				M7040, V7040, M7435, V7435, ML8040, ML9040, LUE7040			
Brass	Needle rollers	Flat	1	E-H MS	E-HW30 F	1'117	M7845, V7845, M8050, V8050, ML9050, ML10050, LUE8050	
					E-H15 MS	234	S4025, J4025, S5025, J5025, LUE5025	
					E-H20 MS	389	S5030, J5030	
		Flat	2	E-H ZW MS	E-H25 MS	575	S5530, J5530	
					E-H19 ZW MS	230	Special rails	
					E-H24 ZW MS	306	S6035, J6035, LUE6035	
					E-H34 ZW MS	499	S7040, J7040, LUE7040	
					E-H44 ZW MS	798	S8050, J8050, LUE8050	
		Angled	2	E-HW MS	E-H55 ZW MS	1'178	Special rails	
					E-HW10 MS	230	M3015, V3015, M3115, V3115	
					E-HW15 MS	306	M4020, V4020, M4422, V4422, M5025, V5025, M5225, V5225, ML5020, ML5520, ML5525, ML6025, ML6525, ML7025, LUE5025	
					E-HW16 MS	390	M5025, V5025, ML5525, ML6025, ML6525, ML7025	
					E-HW20 MS	499	M6035, V6035, M6230, V6230, ML7035, ML8035, LUE6035	
					E-HW25 MS	798	M7040, V7040, M7435, V7435, ML8040, ML9040, LUE7040	
		Needle rollers with damping	Flat	1	E-HG	E-HW30 MS	1178	M7845, V7845, M8050, V8050, ML9050, ML10050, LUE8050
						E-HG10	130	S3525, J3525, LUE5025
						E-HG15	230	S4025, J4025, J5025, LUE5025
						E-HG20	375	S5030, J5030
			Angled	2	E-HGW	E-HG25	560	S5530, J5530
						E-HGW15	265	M4020, V4020, M4422, V4422, M5025, V5025, M5225, V5225, ML5020, ML5520, ML5525, ML6025, ML6525, ML7025, LUE5025
E-HGW20	470					M6035, V6035, M6230, V6230, ML7035, ML8035, LUE6035		
E-HGW25	760					M7040, V7040, M7435, V7435, ML8040, ML9040, LUE7040		
E-HGW30	1'150					M7845, V7845, M8050, V8050, ML9050, ML10050, LUE8050		

9

ACCESSORIES

END PIECES / WIPERS FOR
GUIDEWAYS / ESM INSERT
NUTS FOR GUIDEWAYS

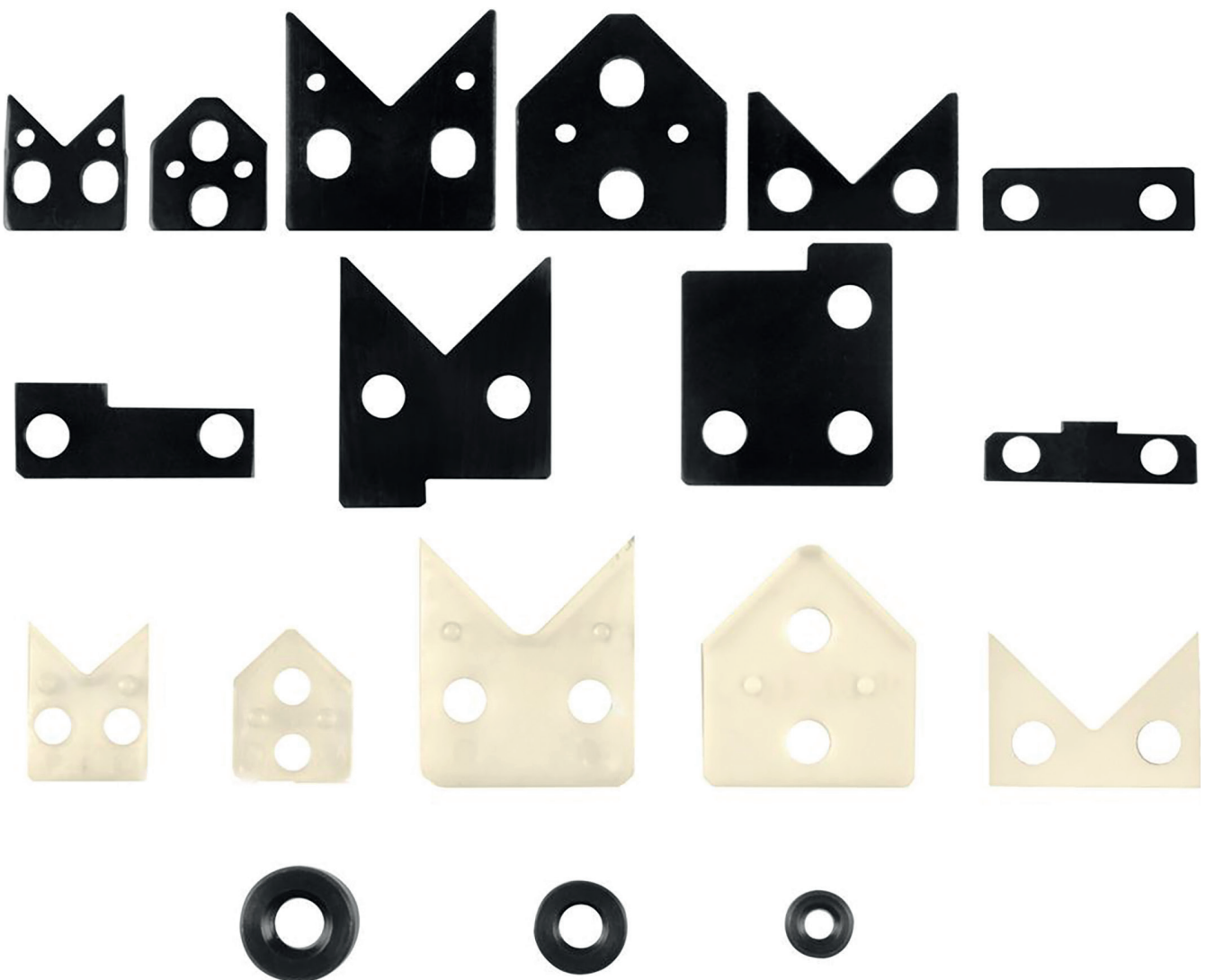

END PIECES

Package contents and use: end piece with fixing screws

- MATERIAL

Blackened construction steel St 37-2
Fixing screws ISO 7984

IMPORTANT INFORMATION: the end pieces must not be used to limit the stroke.

END PIECES AND SCRAPERS

Package contents and use: end piece with assembled wiper plate and fixing screws

- MATERIAL

Blackened construction steel St 37-2
Polyester elastomer
Fixing screws DIN 7984

Longitudinal seals may also be applied in order to reduce the risk of soiling on the raceways.

ESM INSERT NUTS

Standard guideways are delivered with sinkholes (T15). These guideways can be attached as with a threaded hole (T03) by using ESM insert nuts. The insert nuts must be glued into the hole.

The ESM insert nuts should be ordered separately and are delivered loose.

- MATERIAL

Steel CK 45 blackened (1.1191)

END PIECES

EV TYPE

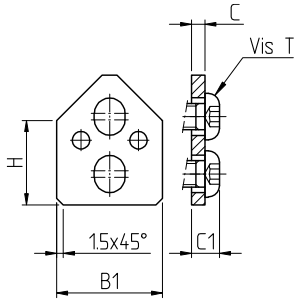

EM TYPE

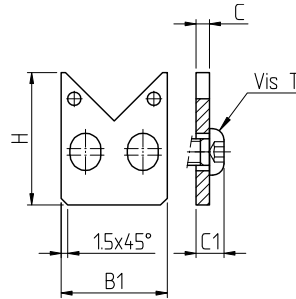

EML TYPE

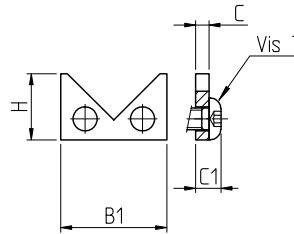

EJ TYPE

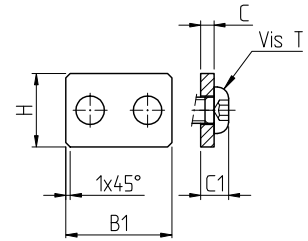

DIMENSIONS IN (MM)

Guideways	Designation				Dimensions				T-screws
	EV	EM	EML	EJ	B1	H	C	C1 max.	DIN 7984
V3015	EV3015				14	12.6	2	4.5	M3x6
V4020	EV4020				19	14.9	3	7	M5x10
V4525	EV4525				24	18.5	3	7.5	M6x10
V5025	EV5025				24	17.8	3	7.5	M6x10
V6035	EV6035				34	21.5	3	7.5	M6x10
V6535	EV6535				34	27.5	3	7.5	M6x10
V7040	EV7040				39	26.2	3	7.5	M6x10
V8050	EV8050				49	29	3	7.5	M6x10
V8550	EV8550				49	37.5	3	7.5	M6x10
M3015		EM3015			14	16.7	2	4.5	M3x6
M4020		EM4020			19	23	3	7	M5x10
M4525		EM4525			24	26.5	3	7.5	M6x10
M5025		EM5025			24	29	3	7.5	M6x10
M6035		EM6035			34	36	3	7.5	M6x10
M6535		EM6535			34	40.5	3	7.5	M6x10
M7040		EM7040			39	42	3	7.5	M6x10
M8050		EM8050			49	49	3	7.5	M6x10
M8550		EM8550			49	54.5	3	7.5	M6x10
ML5020, ML5520			EML 20		19	12	3	6.5	M4x10
ML5525 bis ML7025			EML 25		24	15	3	7	M5x10
ML7035, ML8035			EML 35		34	23	3	7.5	M6x10
ML8040, ML9040			EML 40		39	28.5	3	7.5	M6x10
ML9050, ML10050			EML 50		49	35	3	7.5	M6x10
J3525				EJ3525	34	11	3	7	M5x10
J4025				EJ4025	39	12	3	7	M5x10
J5025				EJ5025	24	16.6	3	7.5	M6x10
J5030				EJ5030	49	14	3	7.5	M6x10
J5530				EJ5530	54	15	3	7.5	M6x10
J6035				EJ6035	34	17	3	7.5	M6x10
J7040				EJ7040	39	16.8	3	7.5	M6x10
J8050				EJ8050	49	18.2	3	7.5	M6x10

END PIECES

ELU TYPE

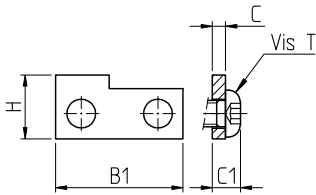

EMLU TYPE

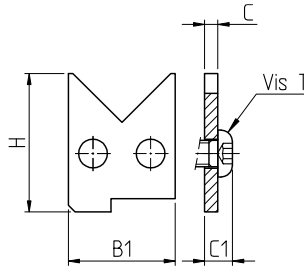

EJLU TYPE

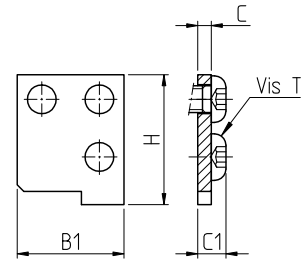

DIMENSIONS IN (MM)

Guideways	Designation			Dimensions				T-screws
	ELU	EMLU	EJLU	B1	H	C	C1 max.	DIN 7984
LUE 5025	ELU 5025			28.6	11.3	3	7.5	M6x10
		EMLU5025		24	31.1	3	7.5	M6x10
			EJLU 5025	24	29.2	3	7.5	M6x10
LUE 6035	ELU 6035			38.6	13.8	3	7.5	M6x10
		EMLU6035		34	40.5	3	7.5	M6x10
			EJLU 6035	34	39	3	7.5	M6x10
LUE 7040	ELU 7040			38.6	15.8	3	7.5	M6x10
		EMLU7040		39	46.5	3	7.5	M6x10
			EJLU 7040	39	44	3	7.5	M6x10
LUE 8050	ELU 8050			49.6	18.8	3	7.5	M6x10
		EMLU8050		49	53.5	3	7.5	M6x10
			EJLU 8050	49	49	3	7.5	M6x10

WIPERS

EAV TYPE

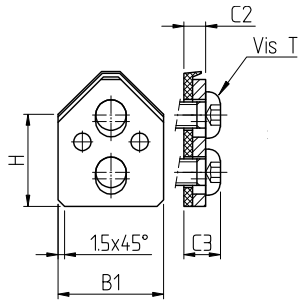

EAM TYPE

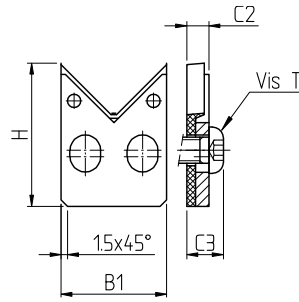

EAML TYPE

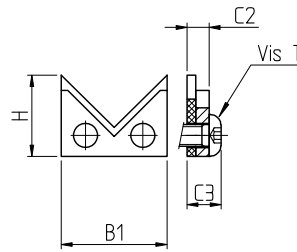

EAJ TYPE

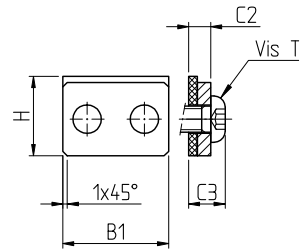

AFFILIATION TABLE

Guideways	Endpieces with assembled wipers	Dimensions				T-screws
		B1	H	C2	C3	DIN 7984
V3015	EAV3015	14	12.6	4	7	M3x8
V4020	EAV4020	19	14.9	5	9	M5x12
V4525	EAV4525	24	18.5	5	9,5	M6x12
V5025	EAV5025	24	17.8	5	9,5	M6x12
V6035	EAV6035	34	21.5	5	9,5	M6x12
V6535	EAV6535	34	27.5	5	9,5	M6x12
V7040	EAV7040	39	26.2	5	9,5	M6x12
V8050	EAV8050	49	29	5	9,5	M6x12
V8550	EAV8550	49	37.5	5	9,5	M6x12
M3015	EAM3015	14	16.7	4	7	M3x8
M4020	EAM4020	19	23	5	9	M5x12
M4525	EAM4525	24	26.5	5	9,5	M6x12
M5025	EAM5025	24	29	5	9,5	M6x12
M6035	EAM6035	34	36	5	9,5	M6x12
M6535	EAM6535	34	40.5	5	9,5	M6x12
M7040	EAM7040	39	42	5	9,5	M6x12
M8050	EAM8050	49	49	5	9,5	M6x12
M8550	EAM8550	49	54.5	5	9,5	M6x12
ML5020, ML5520	EAML 20	19	12	5	8,5	M4x12
ML5525 bis ML7025	EAML 25	24	15	5	9	M5x12
ML7035, ML8035	EAML 35	34	23	5	9,5	M6x12
ML8040, ML9040	EAML 40	39	28.5	5	9,5	M6x12
ML9050, ML10050	EAML 50	49	35	5	9,5	M6x12
J3525	EAJ3525	34	11	5	9	M5x12
J4025	EAJ4025	39	12	5	9	M5x12
J5025	EAJ5025	24	16.6	5	9,5	M6x12
J5030	EAJ5030	49	14	5	9,5	M6x12
J5530	EAJ5530	54	15	5	9,5	M6x12
J6035	EAJ6035	34	17	5	9,5	M6x12
J7040	EAJ7040	39	16.8	5	9,5	M6x12
J8050	EAJ8050	49	18.2	5	9,5	M6x12

ESM INSERT NUTS

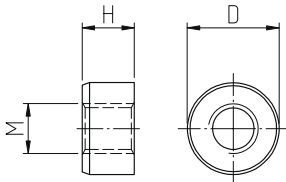

DIMENSIONS IN (MM)

Guideways	Designation	Dimensions		
	ESM	D -0.05/-0.10	H	M
M/V 3015	ESM M4	8.5	4.3	M4
S/J 3525 - S/J 4025	ESM M5	10	5.5	M5
M/V 4020 - M/V 4525 - M/V 5025 S/J 5025 ML 5020 - ML 5520 ML 5525 - ML 6025 ML 6525 - ML 7025	ESM M6	11.5	6.5	M6
S/J 5030 - S/J 5530	ESM M6	11	6.5	M6
M/V 6035 - M/V 6535 S/J 6035 ML 7035 - ML 8035	ESM M8	15	8.5	M8
M/V 7040 S/J 7040 ML 8040 - ML 9040	ESM M10	18.5	10.5	M10
M/V 8050 - M/V 8550 S/J 8050 ML 9050 - ML 10050	ESM M12	20	12.5	M12

ESM are used to adapt a standard rail (T15 bore) for fixation from the frame. (T03 hole principle)

It remains technically and economically preferable to use the T03 hole solution if the rail fixing principle is known at the time of the request.

10

ALTERNATIVE VERSIONS

GROUP	DETAILS	CODE	
No threaded holes on front side	No threaded holes on both ends	E1	
	No threaded holes at beginning of the guideway (L1)	E1L	
	No threaded holes at end of the guideway (L2)	E1R	
Raceway lead areas at end of guideways	Raceway lead areas at both ends of the guideway	E2	
	Raceway lead area at beginning of the guideway (L1)	E2L	
	Raceway lead area at end of the guideway (L2)	E2R	
Position of fixing holes different from dimension table	Distance between the first hole and the start of the guideway	L1	
	Hole distance	LA	
	Distance between the last hole and the end of the guideway	L2	
Layout with longitudinal seal		Layout with longitudinal sealing tapes made from plastic	PP
		Layout with longitudinal sealing tapes made from steel	ZZ
Raceways with sliding layer	With Turcite sliding layer	LB	
	With Permaglide sliding layer	LP21	
Layout with integrated toothed rack	For positive control of flat cage assemblies	MVZ	

GROUP	DETAILS	CODE
Special treatments	Corrosion protection – thin layer chromium plating (layer thickness 2-5µm)	DSV
	Galvanising – nickel coating – blackening – sandblasting – trovalisation procedures, etc.	AVAILABLE ON REQUEST
Special tolerances	Pre-ground raceways	VQ10
	Special height dimension (H)	TH
	Restricted width tolerance	TB
	Restricted hole distance tolerance (LA)	P
	Lubrication holes or additional holes	TG
	Ground joints for multi-part guideways	E5
	Guideways with joints ground on both sides	E6
Different guideway materials	Stainless or other steel	AVAILABLE ON REQUEST

11

SPECIAL DESIGNS



GUIDEWAYS FOR CROSSED ROLLER AND BALL FLAT CAGE ASSEMBLIES R3/R6/R9...



GUIDEWAYS FOR HYDROSTATIC GUIDANCE SYSTEMS



GUIDEWAYS FOR AIR BEARINGS



SPECIFIC SHAPES AND DIMENSIONS

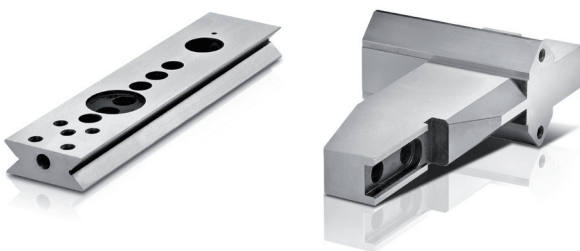

LINEAR RECIRCULATING ROLLER BEARINGS (RUSW + U-100)

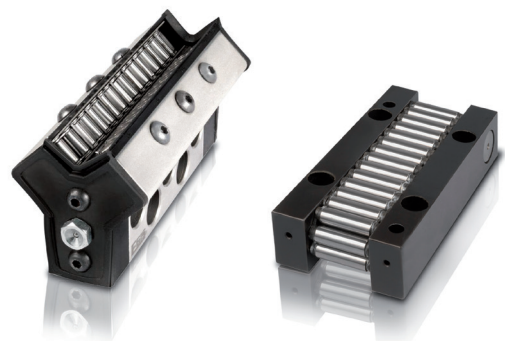

SPECIAL MATERIALS

Stainless or other steel available on request

NOTES



EGIS SA
RUE EUGÈNE-DE-COULON 5
2022 BEVAIX
SWITZERLAND
TEL. +41 (0)32 846 16 22
FAX +41 (0)32 846 27 30

egis@egis-sa.com
www.egis-sa.com

